

Three Phase Motor Controller Installation Instructions

8040366
Rev. 100 (3/2002)

The information in this document is believed to be accurate and reliable. However, Helix Technology Corporation, cannot accept any financial or other responsibilities that may result from the use of this information. No warranties are granted or extended by this document.

Helix Technology Corporation reserves the right to change any or all information contained herein without prior written notice. Revisions may be issued at the time of such changes and/or deletions.

Any duplication of this manual or any of its parts without expressed written permission from Helix Technology Corporation is strictly prohibited.

Any correspondence regarding this document should be forwarded to:

Helix Technology Corporation
Mansfield Corporate Center
Nine Hampshire Street
Mansfield, Massachusetts 02048-9171 U.S.A.

Telephone: (508) 337-5000
FAX: (508) 337-5464

The following Helix Technology Corporation trademarks and service marks may appear in this document:

Conductron™	Convectron®	Cryodyne®	Cryogen®
Cryogenerator®	Cryo-Torr®	CTI-Cryogenics®	FastRegen™
GOLDLink®	Granville-Phillips™	GUTS®	Helix Technology.. Your Vacuum Connection SM
Helix®	Micro-Ion®	Mini-Ion™	On-Board®
RetroEase®	RetroFast®	Stabil-1®	Stabil-Ion®
ThinLine™	TurboPlus®	Vacuum Assurance SM	

All other trademarks or registered trademarks are the property of their respective holders.

Table of Contents

Safety

- S.1 Introduction S-1
- S.2 Warnings S-1
 - S.2.1 Toxic, Corrosive, Dangerous Gases, or Liquids S-1
 - S.2.2 Flammable or Explosive Gases S-1
 - S.2.3 High Voltage S-2
 - S.2.4 High Gas Pressure S-2
- S.3 Cautions S-2
- S.4 Cryopump Oxygen Procedures S-2

Section 1 - Introduction

- Introduction 1-1
- Specifications 1-1
- Dimensions 1-3

Section 2 - Installation

- Introduction 2-1
- 9700A Compressor Cable Connections 2-1
- 9600 Compressor Cable Connections 2-3
- 8200 Compressor Cable Connections 2-5
- 8500 Compressor Cable Connections 2-7
- 8510 Compressor Cable Connections 2-9
- 1020R Compressor Cable Connections 2-11
- Electrical Preparation of Compressors 2-13
 - 9700A and 9600 Compressors 2-13
 - 8500 Compressor 2-13
 - 8200 Compressor 2-14
 - 8510 Low Voltage Compressor Control Module 2-16
 - 8510 High Voltage Compressor Control Module 2-17
 - 1020R Compressor Control Module 2-18

Appendix A - Customer Support Information

Appendix B - Schematic

Index

Table of Contents (continued)

Figures

Figure 1-1: Three Phase Motor Controller	1-2
Figure 1-2: Three Phase Motor Controller Dimensions	1-3
Figure 2-1: 9700A Compressor Cable Connections	2-2
Figure 2-2: 9600 Compressor Cable Connections	2-4
Figure 2-3: 8200 Compressor Cable Connections	2-6
Figure 2-4: 8500 Compressor Cable Connections	2-8
Figure 2-5: 8510 Compressor Cable Connections	2-10
Figure 2-6: 1020R Compressor Cable Connections	2-12
Figure 2-7: 8500 Compressor Control Module	2-14
Figure 2-8: 8200 Compressor Power Selector Switches	2-14
Figure 2-9: 8510 Low Voltage Compressor Control Module	2-16
Figure 2-10: 8510 High Voltage Compressor Control Module	2-17
Figure 2-11: 1020R Compressor Control Module Modifications (Cover Removed)	2-20
Figure B-1: Three Phase Motor Controller Electrical Schematic P/N 8124061P001 Rev. A	B-2

Tables

Table 1-1: Three Phase Motor Controller Specifications	1-1
Table 2-1: Three Phase Motor Controller Power Cable Applications for 8200 Compressors	2-6
Table 2-2: 8500 Compressor Voltage Selector Switch Settings	2-13
Table 2-3: 8200 Compressor Power Requirements	2-15
Table 2-4: 8200 Compressor Power Requirements (Steady-State Conditions)	2-15
Table 2-5: 8510 Low Voltage Compressor S3 Switch Settings	2-16
Table 2-6: 8510 High Voltage Compressor S2 and S3 Switch Settings	2-17
Table 2-7: 1020R Compressor Control Module Transformer T1 and T2 Tap Settings	2-19
Table 2-8: 1020R Compressor Voltage Adjustment Switch Positions	2-19
Table A-1: CTI-CRYOGENICS Product Customer Support Centers	A-2

Safety

S.1 Introduction

On-Board products have been designed to provide extremely safe and dependable operation when properly used. Safety precautions must be observed during normal operation and when servicing the On-Board system.

NOTE: Read this manual and follow these safety guidelines before installing, operating, or servicing On-Board products.

S.2 Warnings

A warning describes safety hazards or unsafe practices which could result in personal injury or loss of life. A warning message is accompanied by a symbol as described in the following paragraphs and is also surrounded by a box to attract your attention.

S.2.1 Toxic, Corrosive, Dangerous Gases, or Liquids



Toxic, corrosive, dangerous gases, or liquids which may be present in an On-Board product could cause severe injury upon contact. Make sure the following precautions are taken when handling toxic, corrosive, or dangerous gases.



1. Always vent toxic, corrosive, dangerous gases, or liquids to a safe location using an inert purge gas.
2. Clearly identify toxic, corrosive, dangerous gases, or liquids on containers used to store or ship equipment after such exposure.

S.2.2 Flammable or Explosive Gases



Flammable or explosive gases which may be present in an On-Board product could cause severe injury if ignited. Make sure the following precautions are taken when handling flammable or explosive gases:



1. Always vent flammable or explosive gases to a safe location using an inert purge gas.
2. Do not install a hot filament type vacuum gauge on the high vacuum side of the isolation valve. This could be an ignition source of flammable gases in On-Board products.

S.2.3 High Voltage

High voltage electric shock can cause severe injury or loss of life. Take the following precautions to prevent high voltage risks:



1. Disconnect the high vacuum pump system from all power sources before making electrical connections between system components or before performing troubleshooting and maintenance procedures.

S.2.4 High Gas Pressure

High gas pressure may be present within high vacuum pump systems and can cause severe injury from propelled particles or parts.



1. Do not modify or remove the pressure relief valves, either on the On-Board pump or within the helium compressor.
2. Always depressurize the adsorber to atmospheric pressure before disposing.
3. Always bleed the helium charge down to atmospheric pressure before servicing or disassembling the self sealing couplings.

S.3 Cautions

A caution describes safety hazards or unsafe practices which could result in equipment damage.

S.4 Cryopump Oxygen Procedures



WARNING

Combustion supported by oxygen in the cryopump could cause severe injury when oxygen is used as a process gas. Special precautions described in the following text should be taken.

When oxygen is used as a process gas, the following precautions should be taken:

1. Insure that there are no sources of ignition (e.g. hot filament vacuum gauges) on the cryopump side of the high vacuum valve operating during the warming or venting of the cryopump.

2. Perform inert gas purge regeneration cycles at flow rates recommended for cryopumps.
3. Regenerate as frequently as practical to minimize the amount of oxidizer present in the cryopump.
4. It is standard practice in the vacuum industry that any system exposed to richer-than-air oxygen levels should be prepared for oxygen service per the manufacturer's recommendations, including use of oxygen service lubricating oils in roughing pumps.



WARNING

Explosion occurring from ozone in the cryopump could cause severe injury. Ozone can be present as a by product of oxygen processes. If ozone is present, special precautions described in the following text must be taken.

Ozone may be unknowingly produced in an ionizing process (e.g. sputtering, etching, glow discharge). Explosive conditions may exist if ozone is present, especially during the warming of the cryopump. Signs of ozone's presence are:

1. Crackling, popping sounds (as in electrical arcing) occurring within the first few minutes of a regeneration cycle.
2. Gas venting from the cryopump during regeneration may have a pungent smell, similar to that present in an arc welding operation or after an electrical storm.

NOTE: *A change in process may increase the amount of ozone present.*

If ozone is present, the following precautions must be taken:

1. All of the above oxygen precautions must be followed. The required regeneration frequency is dependent upon flow and process conditions. Daily regeneration may be required. Call CTI-CRYOGENICS for assistance.
2. Reduce the oxygen mixture to the lowest level the process will allow.

Section 1 - Introduction

Introduction

The Three Phase Motor Controller P/N 8124063G001, shown in **Figure 1-1**, is designed to provide power for up to three On-Board Cryopumps and can be used with the 9700A, 9600, 8200 (three-phase compressor), 8510, 8500, and 1020R compressors. The dimensions are shown in **Figure 1-2**.

***NOTE:** The Three Phase Motor Controller P/N 8124063G002 is only used with the 8200 single phase compressor. Refer to **Table 2-1** for 8200 Compressor applications.*

Section 2 - Installation provides all the required information for installing and interfacing the Three Phase Motor Controller with each CTI-CRYOGENICS compressor.

Specifications

Table 1-1: Three Phase Motor Controller Specifications

Parameter	Value
Weight	50 lbs (22.67 kg)
Ambient Temperature	50 - 100°F (10 - 38°C)

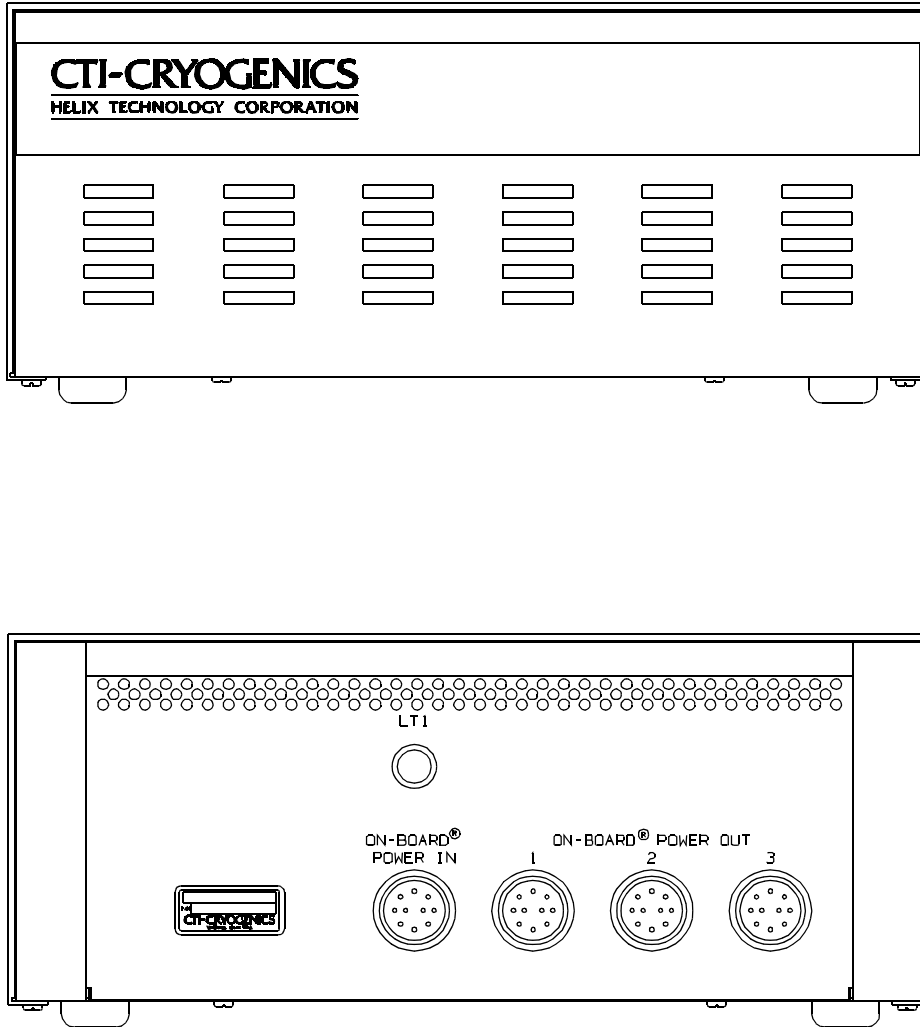

Figure 1-1: Three Phase Motor Controller

Dimensions

The dimensions of the Three Phase Motor Controller are shown in Figure 1-2.

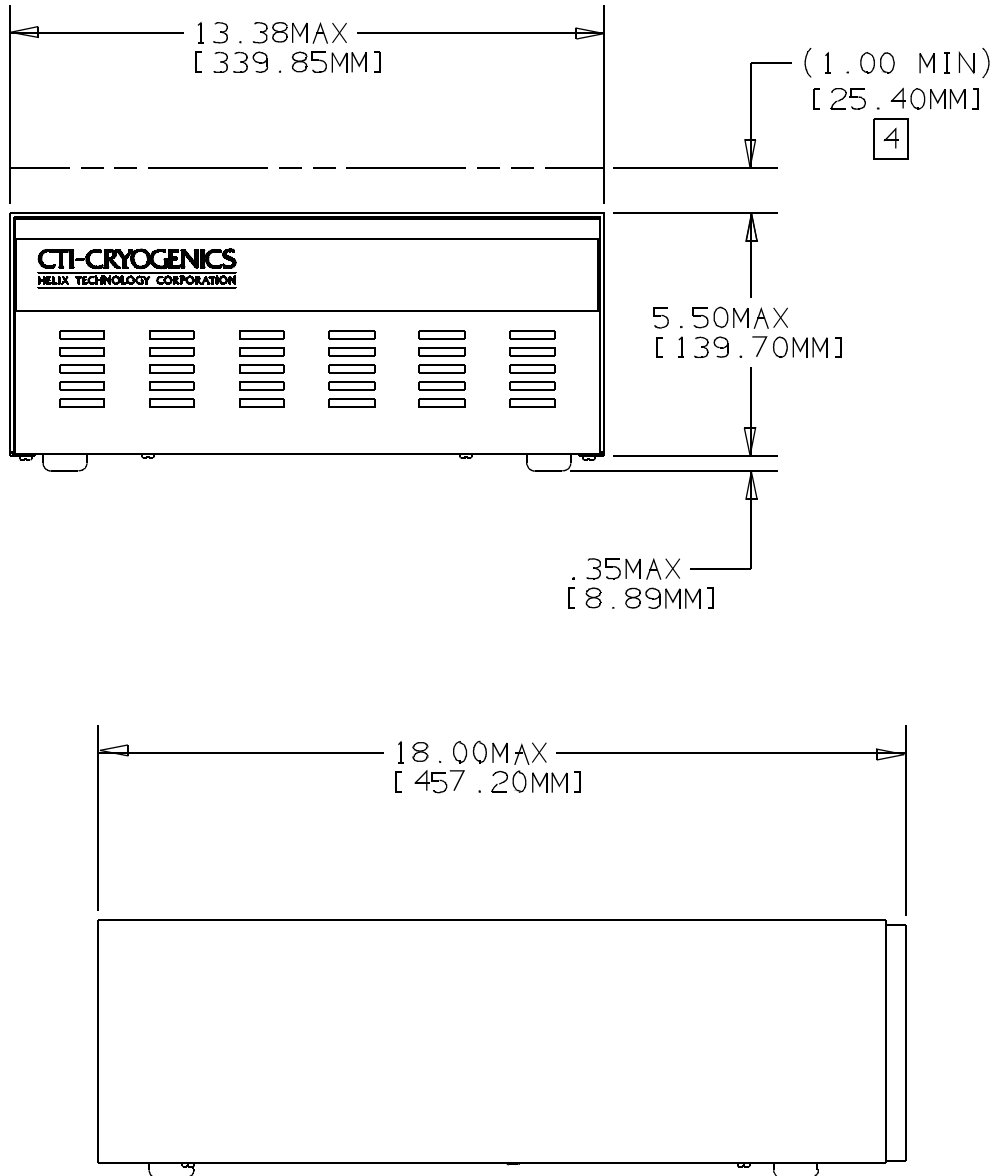

Figure 1-2: Three Phase Motor Controller Dimensions

Section 2 - Installation

Introduction

The 9700A, **9600**, **8200**, **8510**, **8500**, and **1020R** Compressor Cable Connection procedures provide quick access to all required information for interconnecting the Three Phase Motor Controller to each compressor.

Refer to **Electrical Preparation of Compressors** for more information regarding specific cable requirements and electrical preparation of the particular compressor.

9700A Compressor Cable Connections

This procedure involves the following components:

- 9700A Compressor, P/N 8135910G001
- Three Phase Motor Controller P/N 8124063G001 which includes the On-Board power cable P/N 8112463G050

NOTE: Refer to **Figure 2-1** during this procedure.

1. Carefully place the Three Phase Motor Controller on top of the 9700A Compressor.
2. Connect the three On-Board coldhead power cables (customer supplied) to the *On-Board Power* connectors on the rear panel of the Three Phase Motor Controller.
3. Connect the On-Board power cable P/N 8112463G050 (supplied) to the *On-Board Power In* connector on the Three Phase Motor Controller and the On-Board Cryopump electrical outlet on the 9700A Compressor.

CAUTION

ALLOW A 1.0 INCH MINIMUM SPACE ABOVE THE TOP OF THE THREE PHASE MOTOR CONTROLLER FOR ADEQUATE VENTILATION.

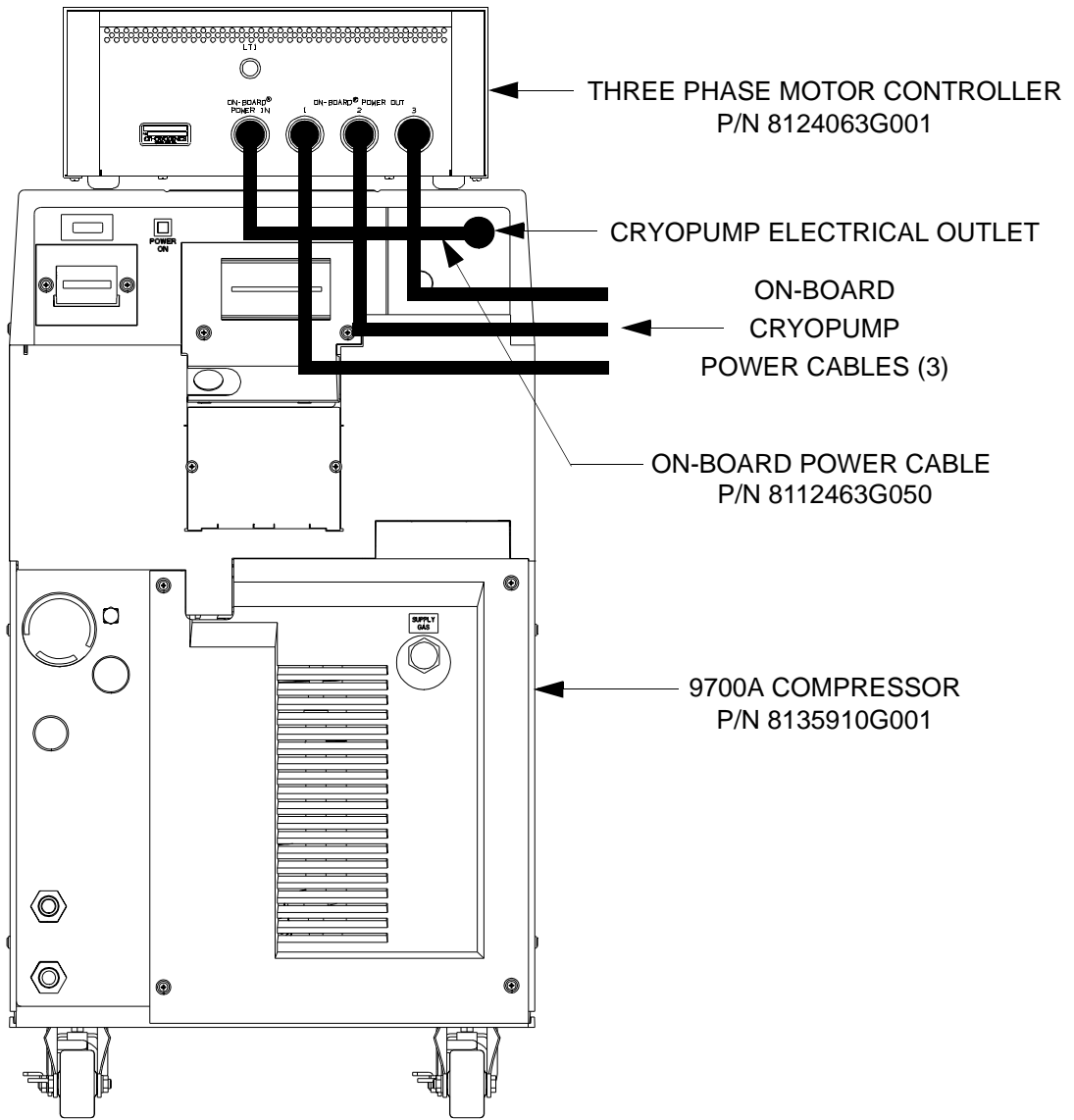

Figure 2-1: 9700A Compressor Cable Connections

9600 Compressor Cable Connections

This procedure involves the following components:

- 9600 Compressor, P/N 8135900GXXX
- Three Phase Motor Controller P/N 8124063G001 which includes the On-Board power cable P/N 8112463G050

*NOTE: Refer to **Figure 2-2** during this procedure.*

1. Carefully place the Three Phase Motor Controller on top of the 9600 Compressor.
2. Connect the three On-Board coldhead power cables (customer supplied) to the *On-Board Power* connectors on the rear panel of the Three Phase Motor Controller.
3. Connect the On-Board power cable P/N 8112463G050 (supplied) to the *On-Board Power In* connector on the Three Phase Motor Controller and the On-Board Cryopump electrical outlet on the 9600 Compressor.

CAUTION

ALLOW A 1.0 INCH MINIMUM SPACE
ABOVE THE TOP OF THE THREE PHASE
MOTOR CONTROLLER FOR
ADEQUATE VENTILATION.

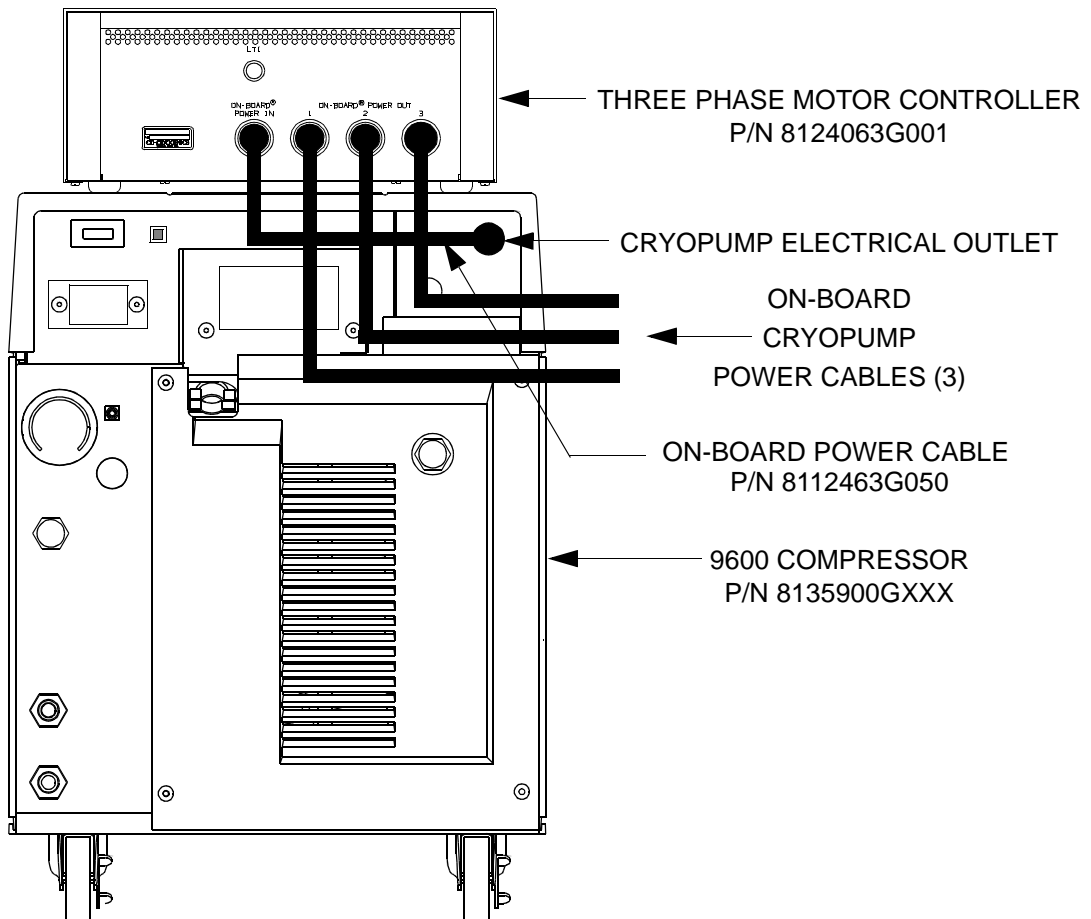

Figure 2-2: 9600 Compressor Cable Connections

8200 Compressor Cable Connections

NOTE: The Three Phase Motor Controller P/N 8124063G002 is only used with the 8200 single phase compressor. Refer to [Table 2-1](#) for 8200 Compressor applications.

This procedure involves the following components:

- 8200 Compressor, P/N 8032549GXXX.
- Three Phase Motor Controller P/N 8124063GXXX which includes the On-Board power cable P/N 8112463G050.

NOTE: Refer to [Figure 2-3](#) during this procedure.

1. Carefully place the Three Phase Motor Controller on top of the 8200 Compressor.
2. Connect the three On-Board coldhead power cables (customer supplied) to the *On-Board Power* connectors on the rear panel of the Three Phase Motor Controller.
3. Connect the On-Board power cable P/N 8112463G050 (supplied) to the *On-Board Power In* connector on the Three Phase Motor Controller and the *On-Board Power* outlet on the 8200 Compressor.

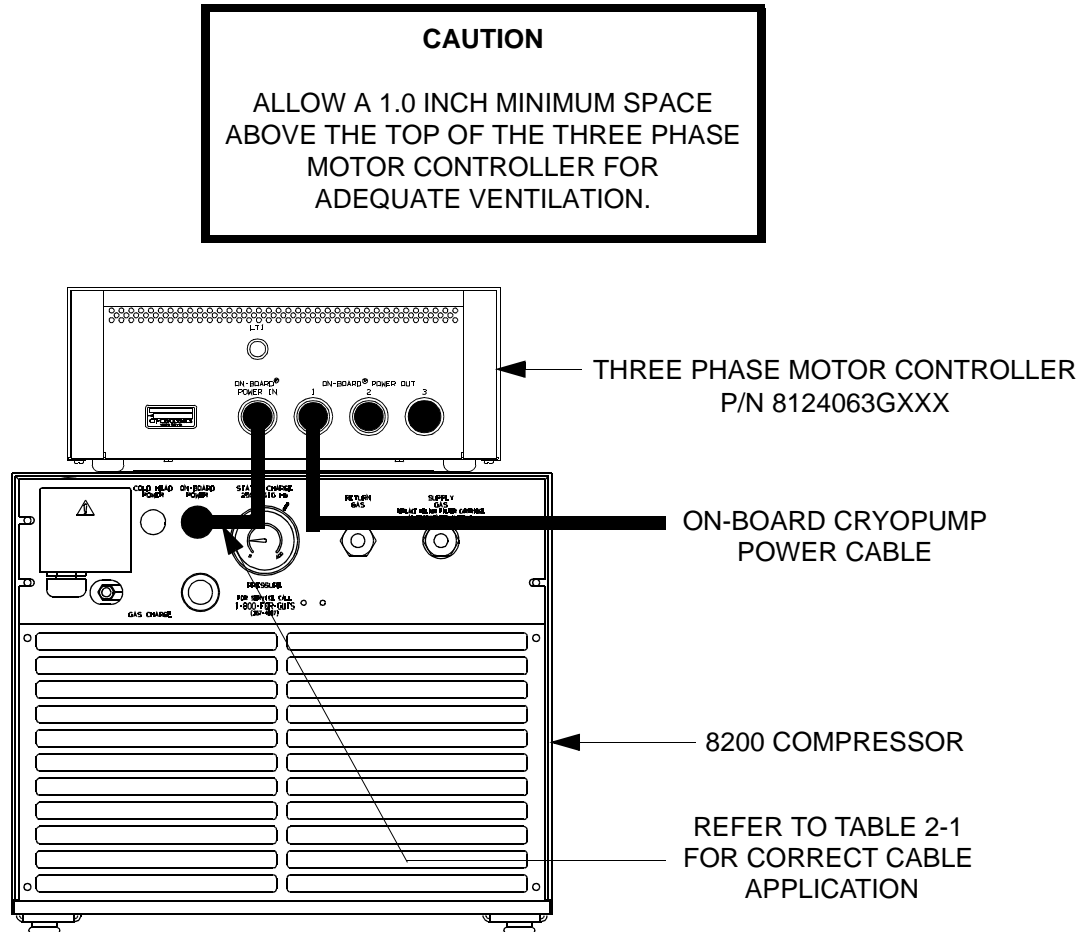

Figure 2-3: 8200 Compressor Cable Connections

Table 2-1: Three Phase Motor Controller Power Cable Applications for 8200 Compressors

Three Phase Motor Controller P/N	8200 Compressor P/N	Power Cable P/N
8124063G001	8032549G001 (water cooled)	8112463G050
8124063G001	8032550G001 (air cooled)	8112463G050
8124063G002	8032550G002 (water cooled)	8043072G050
8124063G002	8032550G002 (air cooled)	8043072G050

8500 Compressor Cable Connections

This procedure involves the following components:

- 8500 Compressor, P/N 8031348G001 or G002
- Three Phase Motor Controller P/N 8124063GXXX which includes the On-Board power cable P/N 8112463G050
- On-Board 8011 Controller P/N 8052300

NOTE: Refer to [Figure 2-4](#) during this procedure.

1. Carefully place the On-Board 8011 Controller on top of the 8500 Compressor.
2. Carefully place the Three Phase Motor Controller on top of the 8500 Compressor.
3. Connect the three On-Board coldhead power cables (customer supplied) to the *On-Board Power* connectors on the rear panel of the Three Phase Motor Controller.
4. Connect the 8500 compressor coldhead power cable P/N 8032222 to the *Coldhead 1 In* connector on the 8011 controller.
5. Connect the On-Board power cable P/N 8112463G050 (supplied) to the *On-Board Power In* connector on the Three Phase Motor Controller and the *Coldhead 1 Out* connector on the 8011 controller.
6. Set the voltage selector switches to the settings as described in [Table 2-2](#) and as shown in [Figure 2-7](#).
7. Place the Compressor and On-Board power switches on the 8500 compressor to the On position.

CAUTION
ALLOW A 1.0 INCH MINIMUM SPACE ABOVE THE TOP OF THE THREE PHASE MOTOR CONTROLLER FOR ADEQUATE VENTILATION.

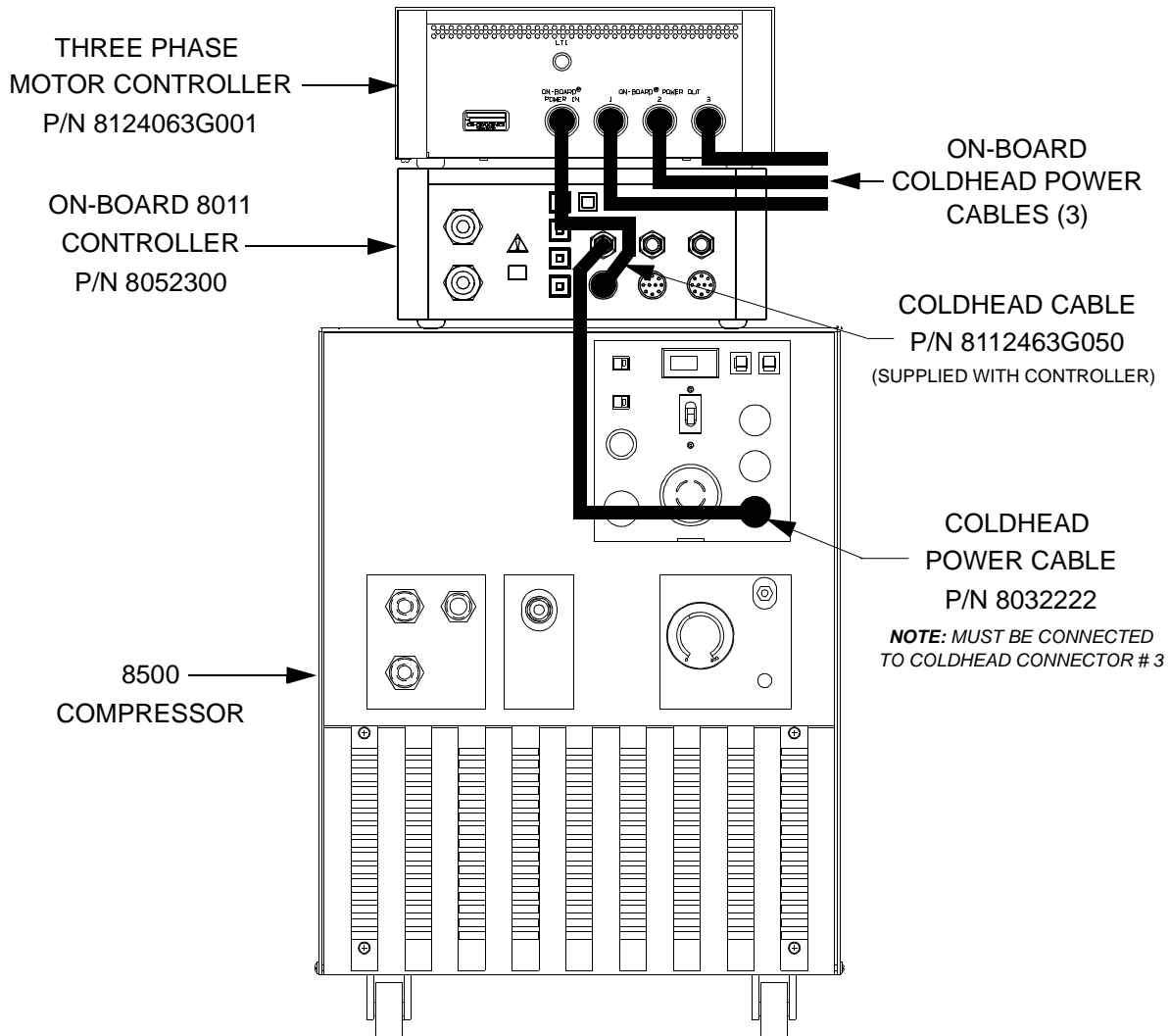

Figure 2-4: 8500 Compressor Cable Connections

8510 Compressor Cable Connections

This procedure involves the following components:

- 8510 Low-Voltage Compressor, P/N 8031315.
- Three Phase Motor Controller P/N 8124063G001 which includes On-Board Power Cable, P/N 8112463G050.

NOTE: Refer to [Figure 2-5](#) during this procedure.

1. Carefully place the Three Phase Motor Controller on top of the 8510 Compressor.
2. Disconnect the three On-Board power cables (customer-supplied) from *Coldhead 1, 2 and 3* connectors on the compressor. Reconnect the cables to the corresponding *On-Board Power Out 1, 2 and 3* connectors on the Three Phase Motor Controller.

NOTE: *NOTE: Make sure the On-Board Power Cable is connected to the correct location as indicated in step 3. The Customer Remote capability will not function if the On-Board Power Cable is connected to Coldhead 1 or 2.*

3. Install the On-Board power cable, P/N 8112463G050 (supplied), between the *On-Board Power In*, connector on the converter and the *Coldhead 3* connector on the compressor.
4. Place the Compressor and On-Board power switches on the 8510 compressor to the ON position.

CAUTION

ALLOW A 1.0 INCH MINIMUM SPACE ABOVE THE TOP OF THE THREE PHASE MOTOR CONTROLLER FOR ADEQUATE VENTILATION.

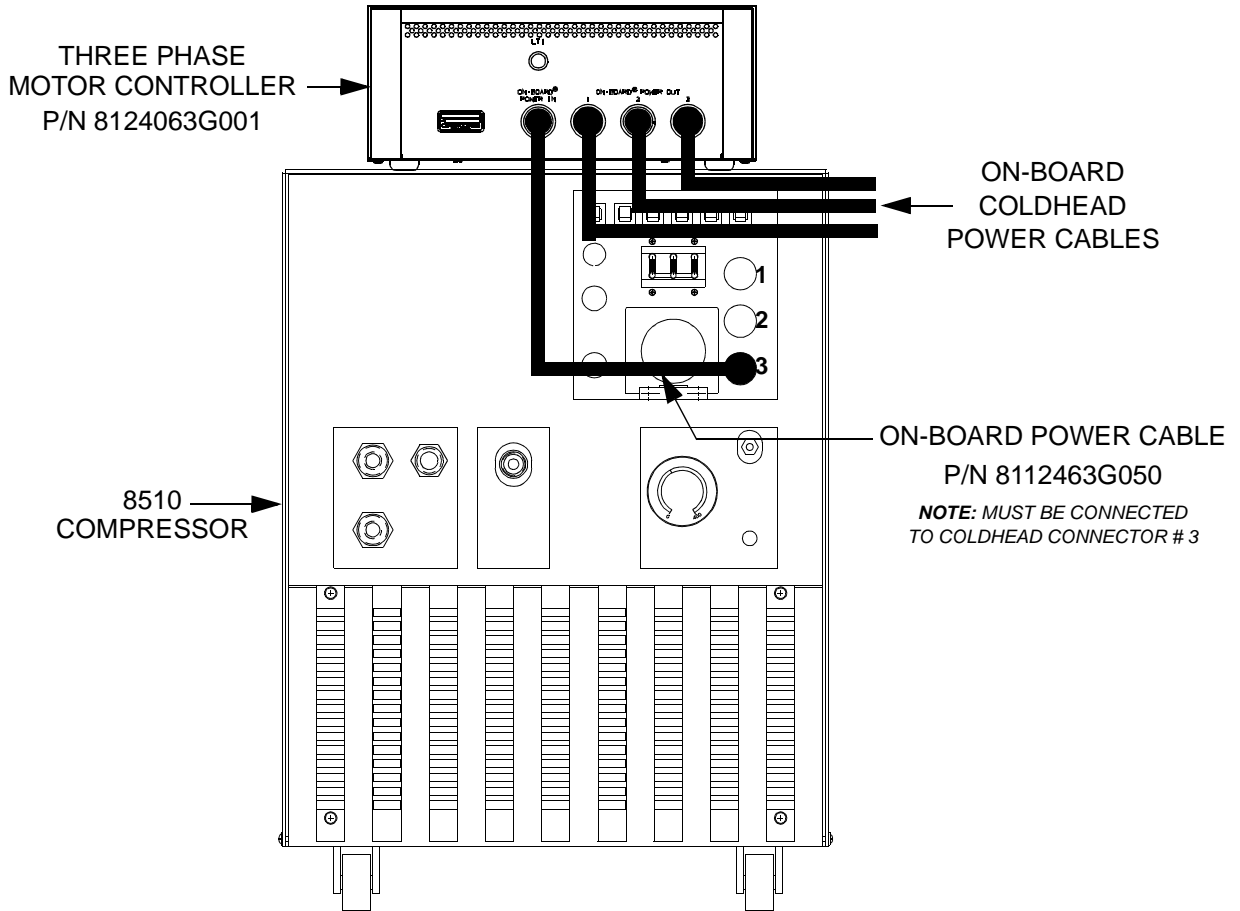

Figure 2-5: 8510 Compressor Cable Connections

1020R Compressor Cable Connections

This procedure involves the following components:

- 1020R Compressor P/N 8031023G001 or G004.
- Three Phase Motor Controller P/N 8124063G001 which includes On-Board Power Cable, P/N 8112463G050.
- On-Board 8011 Controller P/N 8052300.

NOTE: Refer to [Figure 2-6](#) during this procedure.

1. Carefully place the On-Board 8011 Controller on top of the 1020R Compressor.
2. Carefully place the Three Phase Motor Controller on top of the On-Board 8011 Controller.
3. Connect the three On-Board coldhead power cables (customer-supplied) into the *On-Board Power Out 1, 2 and 3* connectors on the Three Phase Motor Controller.
4. Connect the coldhead power cable, hard-wired to the compressor, into the *Coldhead 1 In* connector on the 8011 Controller.
5. Connect the On-Board power cable, P/N 8112463G050 (supplied) to the *On-Board Power In* connector on the converter and the *Coldhead 1 Out* connector on the 8011 Controller.
6. Place the Compressor and On-Board power switches on the 1020R compressor to the On position.

Electrical Preparation of Compressors

9700A and 9600 Compressors

The 9700A and 9600 Compressors will automatically configure all power related settings. All that is required is to connect the Three Phase Motor Controller as shown in [Figure 2-1](#) or [Figure 2-2](#).

8500 Compressor

1. Using a voltmeter, measure the phase-to-phase voltage from the power source.
2. Once the power source phase-to-phase voltage has been measured, refer to Table 2-2 and set the compressor voltage selector switches S2 and S3, as shown in [Figure 2-7](#) to the appropriate range.

Table 2-2: 8500 Compressor Voltage Selector Switch Settings

Configuration	Line Frequency	Line Voltage	S2 Setting	S3 Setting	Coldhead Voltage
P/N 8031348G001 208/230 VAC 50/60Hz	50	190 - 210	2	3	137 - 153
	50	210 - 230	2*	4*	131 - 144
	60	198 - 230	2	3	145 - 169
	60	230 - 250	2*	4*	144 - 158
P/N 8031348G002 380 VAC 50Hz 460VAC 60Hz	50	342 - 400	2	3	126 - 147
	50	400 - 457	2*	4*	125 - 143
	60	395 - 460	2	3	145 - 169
	60	460 - 506	2*	4*	144 - 158
* Factory Setting					

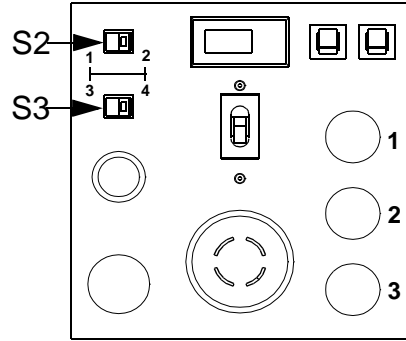

Figure 2-7: 8500 Compressor Control Module

8200 Compressor

The 8200 Compressor requires that the power switches located on the front panel be set to the correct position.

1. Using a voltmeter, measure the phase-to-phase voltage from the power source. Compare this voltage to the following table and position the voltage range selector switch to the 208V or 220V position as required. Also, set the frequency selector switch to the 50 Hz or 60 Hz position, as appropriate. See Figure 2-8 for location of selector switches.

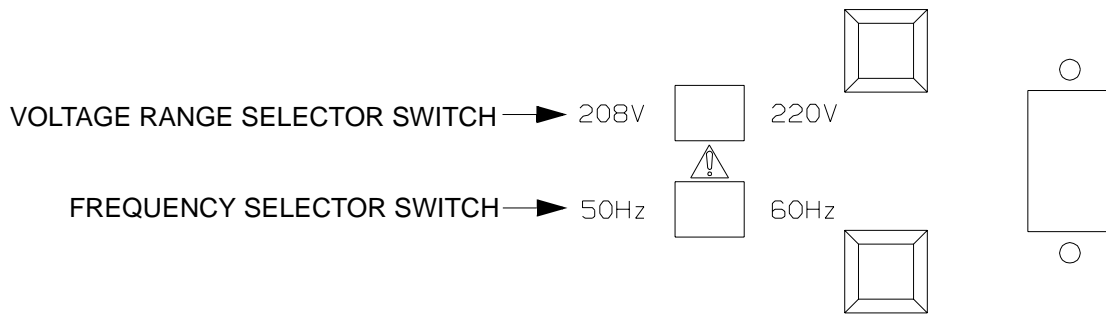

Figure 2-8: 8200 Compressor Power Selector Switches

2. Ensure that water is turned on for the water-cooled compressor.

3. Set the compressor ON/OFF switch to OFF. Connect the input-power cable to the power source Refer to Tables 2-3 and 2-4 for electrical power requirements.

Table 2-3: 8200 Compressor Power Requirements

Operating Voltage Range		Voltage Adjustment Switch S1 Position
60 Hz	50 Hz	
198-212	180-212	208V
213-250	213-220	220V

4. Turn the compressor switch to the ON position and allow the compressor to run for 15 minutes to stabilize the oil circuit. Make sure that the compressor fan operates freely in the air-cooled compressor.
5. Switch off the compressor and disconnect the input-power cable.
6. Install the compressor in its permanent location on a level surface. Air cooled units must have a minimum clearance of 12 inches at the front and back for adequate airflow.

Table 2-4: 8200 Compressor Power Requirements (Steady-State Conditions)

Part Number	Cooling	Phase	Hz	Operating Voltage Range	Nominal Operating Current
8032549G001	Air	3	50	180-220	10A
	Air	3	60	198-250	10A
8032549G002	Air	1	50	180-220	10A
	Air	1	60	198-250	10A
8032550G001	Water	3	50	180-220	8.5A
	Water	3	60	198-250	8.5A
8032550G002	Water	1	50	180-220	8.5A
	Water	1	60	198-250	8.5A

8510 Low Voltage Compressor Control Module

1. Using a voltmeter, measure the phase-to-phase voltage from the power source.
2. Once the power source phase-to-phase voltage has been measured, refer to Table 2-5 and rotate the compressor voltage selector switch S3, as shown in Figure 2-9, to the appropriate position.

Table 2-5: 8510 Low Voltage Compressor S3 Switch Settings

Configuration	Line Frequency	Voltage Range	S3 Position
P/N 8031315 220/230VAC, 50/ 60 Hz	50	190 - 210*	Low
	50	210 - 230	Med
	60	198 - 230*	Low
	60	230 - 250	Med
* Factory Setting			

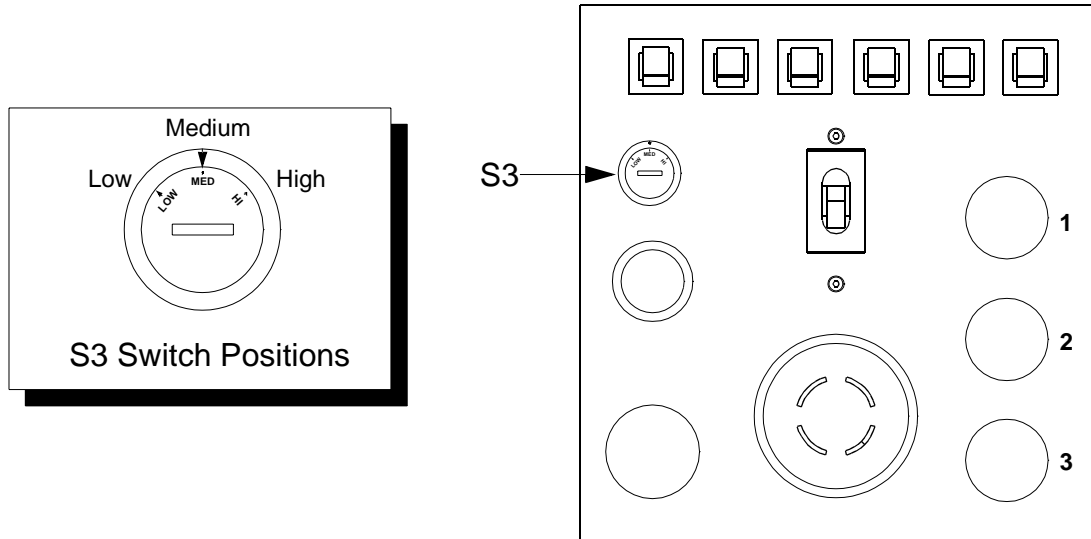

Figure 2-9: 8510 Low Voltage Compressor Control Module

8510 High Voltage Compressor Control Module

1. Using a voltmeter, measure the phase-to-phase voltage from the power source.
2. Once the power source phase-to-phase voltage has been measured, refer to Table 2-6 and set the compressor voltage selector switches S2 and S3, as shown in Figure 2-10, to the appropriate range.

Table 2-6: 8510 High Voltage Compressor S2 and S3 Switch Settings

Compressor Configuration	Line Frequency (Hz)	Voltage	S2 Setting	S3 Setting
P/N 8031400G002 380/460VAC 50/60 HZ	50	342 - 405	2	3
	50	406 - 457	2*	4*
	60	395 - 450	2	3
	60	451 - 506	2*	4*
* Factory Setting				

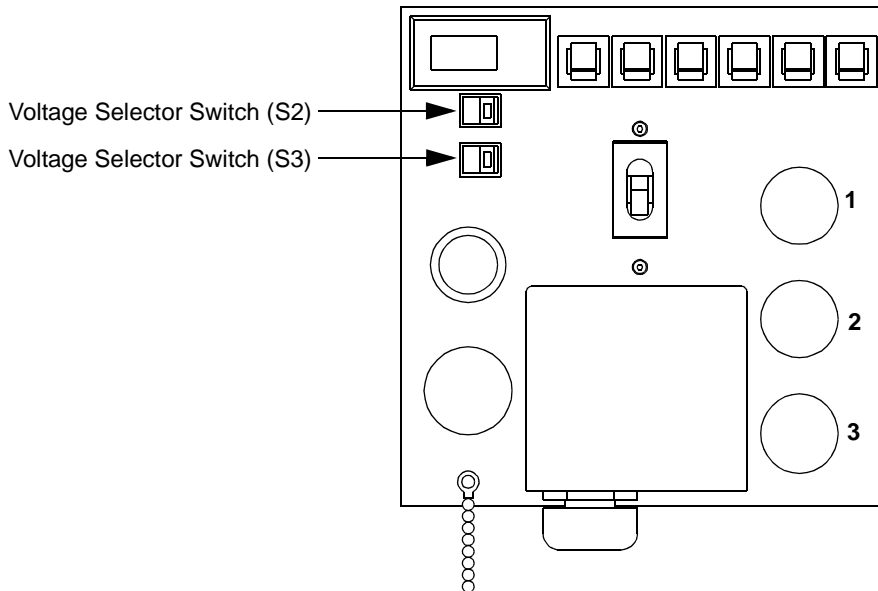

Figure 2-10: 8510 High Voltage Compressor Control Module

1020R Compressor Control Module

1. Remove the top panel of the compressor as follows:
 - a. Remove the two screws from the under side of the top panel that pass through the two brackets at the top of the rear frame and secure the top panel in place.
 - b. Raise the rear of the top panel slightly and push the panel toward the front of the compressor until the slots at the front of the top panel are free of the washer-head screws in the compressor frame.
 - c. Remove the top panel and set it aside.
2. On the compressors that use 380, 400, or 480 volts input power, remove the perforated-metal top cover of the electrical control chassis, and ensure proper input voltage to the coldhead drive motor by making the following output connections for transformer T1 as shown in [Figure 2-11](#). Be sure to replace the perforated-metal cover on the electrical control chassis after the connections are completed.
 - a. Compressors are shipped from the factory with tap 6 of transformer T1 employed for the output connection. Use this connection if the control voltage supplied to the compressor measures 215 VAC or greater.
 - b. If the control voltage supplied to the compressor measures less than 215 VAC, use tap 5 for the output connection. Move the slip-on lug from tap 6 to tap 5.
3. On compressors that use 200/220 and 208/230 volts input power, remove the perforated-metal top cover of the electrical control chassis. Using the phase-to-phase voltage measured from the power source, prepare the *Scott-T* transformers T1 and T2, in accordance with [Table 2-7](#) and [Figure 2-11](#). Be sure to replace the perforated-metal top cover of the electrical control chassis after the connections are completed.
4. Reinstall the top panel on the compressor, ensuring that the slots at the front of the top panel slip past the corresponding washer-head screws that project from the compressor frame.
5. Reinstall the rear panel on the compressor, reactivating the interlock switch.
6. Install the compressor into its permanent location on a level surface. Allow a minimum clearance of 12 inches (30 cm) at the front and back to ensure adequate airflow.

Table 2-7: 1020R Compressor Control Module Transformer T1 and T2 Tap Settings

Line Frequency	Voltage	T1 and T2 Tap Settings
50	190 - 210	B
50	210 - 230*	C
60	198 - 230	B
60	230 - 253*	C
* Factory Setting		

7. Position the voltage adjustment switch (S1) on the On-Board 8011 Controller to the HI or LO position as follows:
 - a. Using a voltmeter, measure the phase-to-phase voltage from the power source.
 - b. Compare this voltage to Table 2-8 and position the voltage adjustment switch located on the 8011 rear panel to the HI or LO position as required.

Table 2-8: 1020R Compressor Voltage Adjustment Switch Positions

Operating Voltage Range	Line Frequency	S1 Position
198 - 230	60	Lo
395 - 450	60	Lo
231 - 250	60	Hi
451 - 506	60	Hi
190 - 204	50	Lo
342 - 400	50	Lo
205 - 240	50	Hi
401 - 457	50	Hi

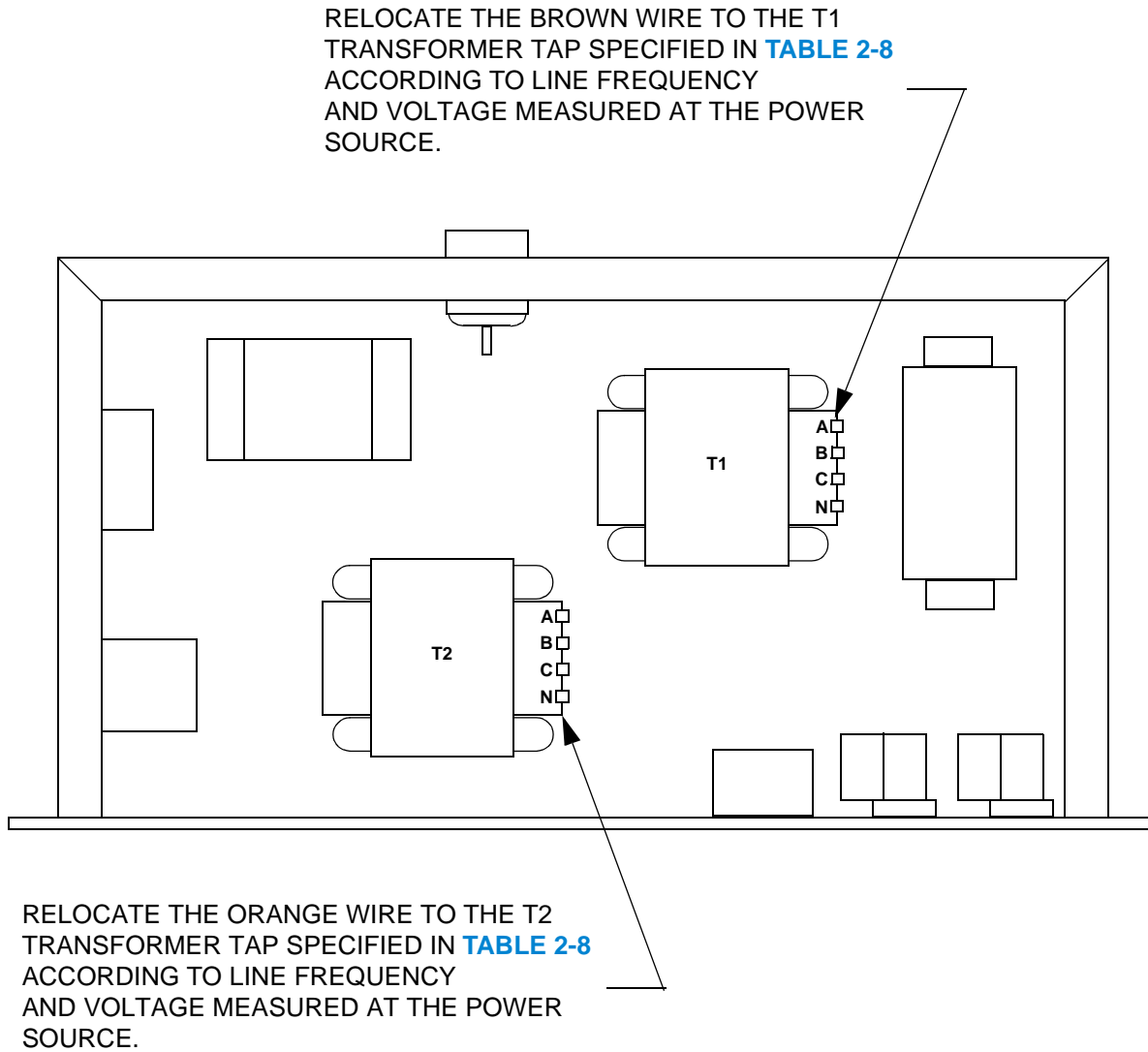

Figure 2-11: 1020R Compressor Control Module Modifications (Cover Removed)

Appendix A - Customer Support Information

Introduction

Refer to Table A-1 for the nearest Customer Support Center for technical assistance or service for CTI-CRYOGENICS products. North American customers may call 800-FOR-GUTS (800-367-4887) 24 hours a day, seven days a week. All other customers must call their local Customer Support Center.

***NOTE:** Please contact the Customer Support Center in Mansfield, Massachusetts in the United States of America by dialing 508-337-5599 if a Customer Support office is not located in your area.*

Please have the following information available when calling so that we may assist you:

- Product Part Number
- Product Serial Number
- Product Application
- Specific Problem Area
- Hours of Operation
- Equipment Type
- Vacuum System Brand/Model/Date of Manufacture

For your convenience, you may also e-mail us at:

contact@helixtechnology.com

Visit us at our corporate website:

www.helixtechnology.com

Table A-1: CTI-CRYOGENICS Product Customer Support Centers

<p>United States and Canada</p> <p>Guaranteed Uptime Support Line GUTS®</p> <p>Dial: 800-FOR-GUTS (800-367-4887) (within USA) 508-337-5599 (outside USA) <i>24 hours a day, seven days a week</i></p> <p>Corporate Headquarters: 800-379-7224 (within USA) 508-337-5000 (outside USA)</p> <p>Austin, TX: 800-324-6445 (within USA) 512-912-2800 (outside USA)</p> <p>Longmont, CO: 800-776-6543 (within USA) 303-652-4400 (outside USA)</p> <p>Santa Clara, CA: 800-324-6449 (within USA) 408-562-5940 (outside USA)</p>	<p>Germany, Italy, Denmark, Switzerland, Holland, Norway, The Netherlands</p> <p>Dial: +(49) 6151-959-55 <i>24 hours a day, seven days a week</i></p>
<p>France, Spain, Portugal, Greece, Belgium, North Africa</p> <p>Dial: +(33) 1-6935-2600 <i>24 hours a day, seven days a week</i></p>	<p>United Kingdom, Ireland, N. Ireland, Scandinavia</p> <p>Dial: +(44) 1-506-460017 <i>24 hours a day, seven days a week</i></p>
<p>Japan</p> <p>Dial: +(81) 0120-60-4887 <i>24 hours a day, seven days a week</i></p>	<p>Korea</p> <p>Dial: +(82) 2-577-3181 <i>24 hours a day, seven days a week</i></p>
<p>Taiwan</p> <p>Dial: +(886) (3) 516-9022 <i>24 hours a day, seven days a week</i></p>	<p>China</p> <p>Dial +(86) 21-6279-1389 <i>24 hours a day, seven days a week</i></p>
<p>Australia, New Zealand, Tasmania</p> <p>Dial: +(612) 9-4810748 <i>24 hours a day, seven days a week</i></p>	<p>Singapore, Malaysia, Philippines, Indonesia</p> <p>Dial: +(65) 268-2024 <i>24 hours a day, seven days a week</i></p>
<p>India</p> <p>Dial: +(91) 22-7632906 <i>24 hours a day, seven days a week</i></p>	<p>Israel</p> <p>Dial: +(972) 3-9247710 <i>24 hours a day, seven days a week</i></p>

Appendix B - Schematic

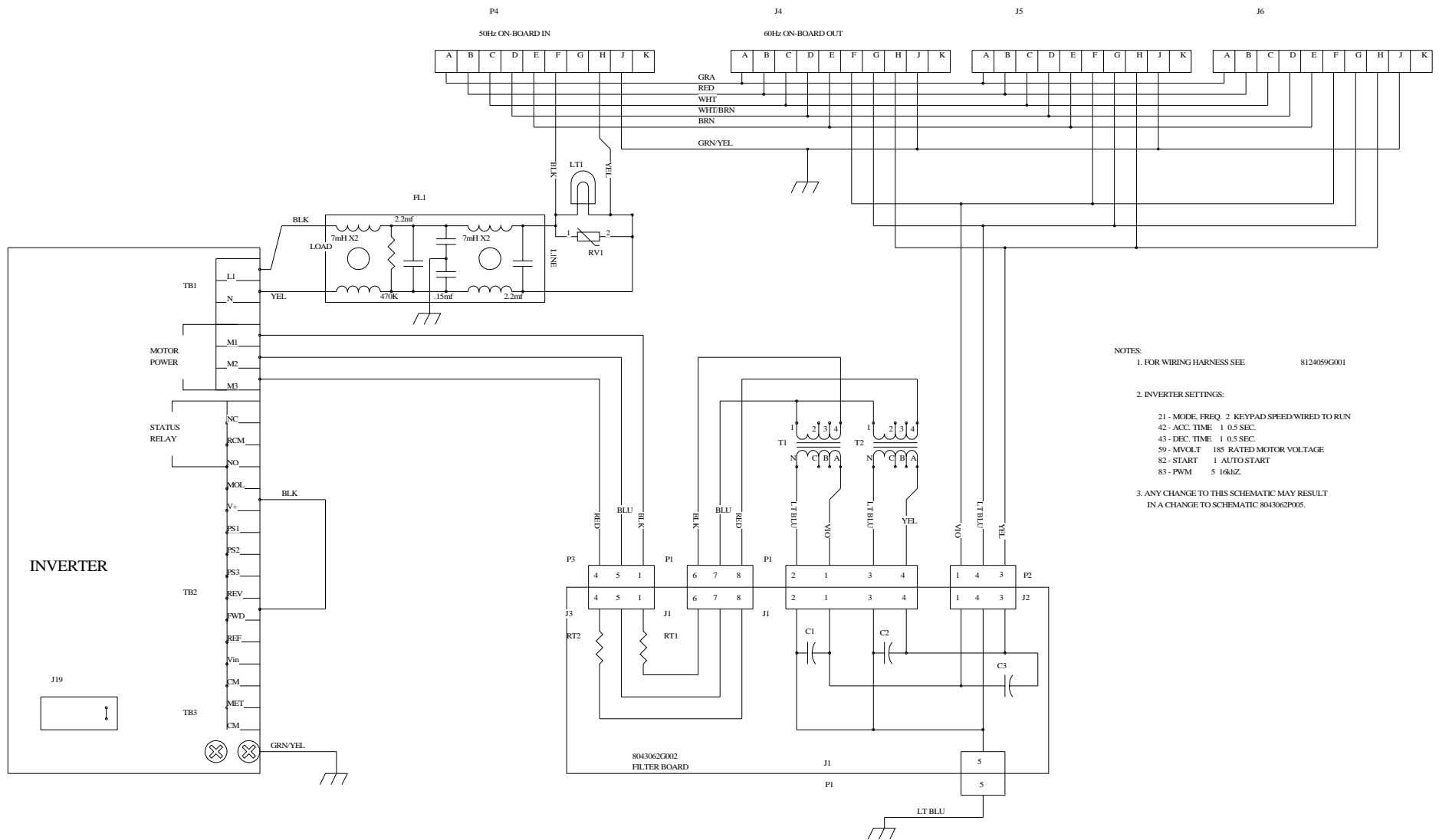

- NOTES:
1. FOR WIRING HARNESS SEE 8124059G001
 2. INVERTER SETTINGS:
 - 21 - MODE, FREQ. 2 KEYPAD SPEED WIRED TO RUN
 - 42 - ACC. TIME 1 0.5 SEC.
 - 43 - DEC. TIME 1 0.5 SEC.
 - 59 - MVOLT 185 RATED MOTOR VOLTAGE
 - 82 - START 1 AUTO START
 - 83 - PWM 5 16kHz.
 3. ANY CHANGE TO THIS SCHEMATIC MAY RESULT IN A CHANGE TO SCHEMATIC 8043062P005.

Figure B-1: Three Phase Motor Controller Electrical Schematic P/N 8124061P001 Rev. A

Index

Numerics

1020R Compressor 2-11
8200 Compressor 2-5
8200 Compressor applications 1-1
8500 Compressor 2-7
8510 Low-Voltage Compressor 2-9
9600 Compressor 2-3
9700A Compressor 2-1

A

Ambient Temperature 1-1
automatically configure 2-13

C

Customer Support Center A-1

D

dimensions 1-3

E

Electrical Preparation 2-13

O

On-Board 8011 Controller 2-7, 2-11
On-Board Cryopumps 1-1

P

phase-to-phase voltage 2-13

S

Safety precautions S-1
Schematic B-1

W

Weight 1-1