

Turbomolecular Drag Pumps With Electronic Drive Units TC 600



***TMH 1601 P / TMU 1601 P
TMH 1601 P C / TMU 1601 P C***

Index

	Page		Page
1. Safety Instructions	3	4.8. Operations With The DCU 001 / DCU 600	16
1.1. For Your Orientation.....	3	4.9. Operations With The Remote Control Unit.....	16
1.2. Pictogramm Definitions.....	3	Venting Release (Optional).....	17
2 Understanding The Pumps		Motor, Turbopump	17
TMH/TMU 1601 P and		Pumping Station	17
TMH/TMU 1601 PC	4	Heating/Reset	17
2.1. Main Features.....	4	Standby.....	17
Proper Use	4	Rotation Speed Setting Operations	
Improper Use	5	Via Input PWM	17
2.2. Differences Between The Pump Types.....	5	Switching Outputs.....	17
2.3. Scope Of Delivery	5	5. Monitoring Operations	18
3. Installation	6	5.1. Operations Display Via LED	18
3.1. Preparations For Installation.....	6	5.2. Turbopump Temperature Monitoring	18
3.2. Installing The Pump, Connecting The		6. What To Do In Case	
High Vacuum Side.....	6	Of Breakdowns?.....	19
Fitting The Splinter Shield (Accessory).....	7	7. Maintenance	20
3.3. Connecting The Fore-Vacuum Side	8	7.1. Replacing The Lubricant.....	20
3.4. Connecting The Cooling Unit.....	8	7.2. Cleaning The Lubricating Pump.....	20
Water Cooling	8	8. Service	22
Air Cooling (Accessory)	9	9. Technical Data	23
3.5. Connecting The Venting Valve.....	9	9.1. Dimensions Diagram	24
3.6. Connecting The Casing Heating Unit		10. Spare Parts	25
(Accessory).....	9	11. Accessories	26
3.7. Connecting The Electronic Drive Unit TC 600.....	10	11.1. Lubricant.....	27
3.8. Installing The Power Unit	10	Declaration of Contamination.....	28
3.9. Connecting The Sealing Gas Valve.....	11	Manufacturer´s Declaration	(last page)
3.10. Connecting The Remote Control Unit	11		
3.11. Connecting The Serial Interface RS 485	12		
Connection	12		
Connecting The RS 485	12		
3.12. Connecting The Temperature			
Management System (TMS)	12		
3.13. Connections Diagram.....	13		
4. Operations	14		
4.1. Filling In The Lubricant.....	14		
4.2. Before Switching ON.....	14		
4.3. Switching ON.....	15		
4.4. Gas Type Dependent Operations	15		
4.5. Circulatory Lubrication.....	16		
4.6. Switching OFF And Venting	16		
4.7. Shutting Down For Longer Periods.....	16		

Please note: Current operating instructions are available via www.pfeiffer-vacuum.net.

1. Safety Instructions

- ☞ Read and follow all instructions in this manual.
- ☞ Inform yourself regarding:
 - Hazards which can be caused by the pump;
 - Hazards which can be caused by your system.
 - Hazards which can be caused by the media being pumped.
- ☞ Avoid exposing any part of the body to vacuum.
- ☞ Observe the safety and accident prevention regulations.
- ☞ Regularly check that all accident prevention measures are being complied with.
- ☞ Do not operate the turbopump with open high vacuum flange.
- ☞ Do not carry out any unauthorised conversions or alterations to the turbopump with TC 600.
- ☞ When returning the turbopump observe the shipping instructions.
- ☞ Use at least 6 bracket screws to connect the high vacuum flange (ISO-flange).
- ☞ The turbopump must be anchored in accordance with the installation instructions.
- ☞ Do not disconnect the plug between the TC 600 and accessory components during operations.
- ☞ Disconnect the voltage supply to the TC 600 before opening the turbopump.
- ☞ When working on the turbopump, the high vacuum flange should only be opened once the rotor is at rest.
- ☞ When using sealing gas, the pressure in the hose connection should be limited to 2 bar via the overpressure valve.
- ☞ If a heater is in use temperatures of up to 120 °C can arise in the area of the high vacuum flange. Take care to avoid burns!
- ☞ During operations temperatures of up to 65 °C can arise in the lower part of the turbopump. Take care to avoid burns!
- ☞ Keep leads and cables well away from hot surfaces (> 70 °C).
- ☞ Operate the turbopump with TC 600 only in conjunction with the relevant power unit (accessory).
- ☞ The unit has been accredited protection class IP 30. When the unit is operated in environments which require other protection classes, the necessary measures must be taken. Protection class IP 54 is afforded by retro-fitting a cover plate (accessory) to the TC 600.
- ☞ The mains connection must be subject to a safe connection to the PE (protection class 1).
- ☞ If the turbopump and the TC 600 are operated separately (only permissible with the agreement of the manufacturer) the turbopump must be connected to the PE.
- ☞ The turbopump and the TC 600 must only be disconnected from each other when the turbopump is completely at rest and the TC 600 has been disconnected from the power supply.
- ☞ The cause of any operating voltage leakage to earth (red LED flashes) must be eliminated to avoid the danger of an electric shock.

Modifications reserved.

1.1. For Your Orientation

Instruction in the text

➔ Working instruction: here, you have to do something.

Symbols used

The following symbols are used throughout in illustrations:

- Ⓜ High vacuum flange
- Ⓥ Fore-vacuum flange
- ⓕ Venting connection
- ⓧ Cooling water connection
- Ⓡ Air cooling
- Ⓛ Electric connection
- Ⓢ Sealing gas connection

Abbreviations used

DCU = Display and operating control unit

TC = Electronic drive unit, turbopump

TPS = Power unit

Position numbers

The same pump and accessory parts have the same position numbers in all illustrations.

1.2. Pictogram Definitions



Danger of burns from touching hot parts.



Danger of personal injury.



Danger of damage to the pump or to the system.



Danger of injury from rotating parts.



Attention to particularly important information on the product, handling the product or to a particular part of the documentation.

2. Understanding The Pumps

TMH/TMU 1601 P And TMH/TMU 1601 PC

2.1. Main Features

Turbopumps TMH/TMU 1601 P/1601 PC with the TC 600 form a complete unit. Voltage is supplied by power unit (see "Accessories").



On delivery, the pumps have been set up for operations in remote mode. Remote plug 8d should therefore be disconnected if operations with the DCU are required.

Bearings

High vacuum side: Wear free permanent magnetic bearing.
Fore-vacuum side: Oil circulatory lubricated ball bearing with ceramic balls.



The turbopumps must **not** be transported when filled with lubricant.
When being fitted into or dismantled from a system, turbopumps may only be positioned as shown in Section 3.2. Other positions can cause the pumps to be contaminated with lubricant.

Turbomolecular Drag Pump TMH/U 1601 P

- 1 High vacuum flange
- 2 Fore-vacuum flange
- 4 Venting screw
- 8 Electronic Drive Unit TC 600
- 8d Remote plug
- 72 Lubricant drain screw
- 73 Sight glass



Proper use

- The Turbomolecular Pumps TMH/TMU 1601 P and TMH/TMU 1601 PC may only be used for the purpose of generating vacuum.
- The Turbomolecular Pumps TMH/TMU 1601 PC (please see the rating plate) are designed to pump corrosive gases and vapours. Where corrosive gas processes are involved, gas bonding and particles which can damage the surfaces of the pump can be produced. The motor and bearing compartments have to be protected with sealing gas.
- The turbopumps may only be used to pump those media against which they are chemically resistant. For other media the operator is required to qualify the pumps for the processes involved.
- If the process produces dust, the maintenance intervals must be specified accordingly and sealing gas must be used.
- If the pump is to be operated with more than 50% of the permissible gas load, sealing gas must be used.
- The turbopump must be connected to a backing pump in accordance with Section 3.3.
- Only Pfeiffer Vacuum power units may be used to operate the TC 600. The use of other power units requires the prior agreement of the manufacturer and equalisation with the valid specification.
- The pumps may only be operated providing the ambient conditions in compliance with Protection Type IP 30 are observed.

Cooling

Standard: Water cooling
Alternative: For the TMH/TMU 1601 P air cooling as an accessory (permissible ambient temperature 35 °C).

Integrated protective measures against excess temperatures:
The Electronic Drive Unit TC 600 reduces the rotor rotation speed.



The TMH/TMU 1601 PC, designed for corrosive gas processes, **must** be water cooled.

Improper use

The following is regarded, inter alia, as improper:

- The pumping of explosive gases.
- Operating the pumps in areas where there is a danger of explosion.
- The pumping of gases and vapours which attack the materials of the pumps.
- The pumping of corrosive gases without sealing gas.
- The pumping of condensating vapours.
- Operations involving impermissibly high levels of gas loads.
- Operations with impermissibly high fore-vacuum pressure.
- Operations with improper gas modes.
- Operations involving too high levels of heat radiation power (see Section 9. "Technical Data").
- Operating the pump in environments which require a protection class superior to IP 30.
- The use of other power units or accessories which are not named in this manual or which have not been agreed by the manufacturer.
- The connection to power units with earthing of a direct voltage pole.

Improper use will cause all claims for liability and guarantees to be forfeited.

2.2. Differences Between The Pump Types

TMH/TMU 1601 P Standard version

TMH/TMU 1601 PC Corrosive gas processes version

Feature	TMH 1601 P TMH 1601 PC	TMU 1601 P TMU 1601 PC
High vacuum flange	ISO-K	CF-F
High vacuum seal	Elastomer	Metal
Attainable final pressure	< 1 · 10 ⁻⁸ mbar (without baking-out)	< 1 · 10 ⁻¹⁰ mbar (with baking-out)

Abbreviations on the rating plate of the pump

TMH /TMU 1601

- Suffix "P": Purge gas connection for the prevention of the ingress of aggressive gases into the motor and bearing area
- Suffix "C": Surface protection for passive protection of the pump
- Suffix "H": High level gas throughputs for process technology
- Suffix "T": Integrated temperature management system

2.3. Scope Of Delivery

The turbopump scope of delivery includes:

- Lubricant F3 (65 cm³) with filling syringe.

3. Installation

3.1. Preparations For Installation



Do not carry out any unauthorised conversions or alterations to the turbopump.

- Pumps must be filled with lubricant before being operated (please refer to Section 4.1.).
- The turbopumps must **not** be transported when filled with lubricant.
- If the turbopump is to be operated with the DCU, the remote plug 8d on the TC should be disconnected (please see Section 2.1.) and then proceed in accordance with Operating Instructions "Pumping Operations With The DCU", PM 800 547 BN.
- The maximum permissible rotor temperature of the pump is 120 °C. If the vacuum chamber or parts in the vacuum chamber are heated, the values stated in the technical data relating to the level of heat which may be radiated into the pump must not be exceeded. If necessary, suitable shielding must be fitted in the vacuum chamber before the turbopump (constructional suggestions available on request).
- Only remove the blank flange from the high and for-vacuum side immediately before connection.
- Where magnetic fields of > 3 mT are involved suitable shielding must be provided (available on request).
- If the pump is baked out, the heating sleeve and the body of the pump must be insulated to prevent burns from accidental contact.
- In the event of a sudden standstill of the rotor, torques of up to 8270 Nm can arise and these must be taken up by the turbopump and frame. Pumps must be anchored as follows:
 - ISO flange with 8 bracket screws, or
 - CF flange with the complete set of M8 screws, or
 - underside of the pump with 4 screws M8, screws quality 8.8.

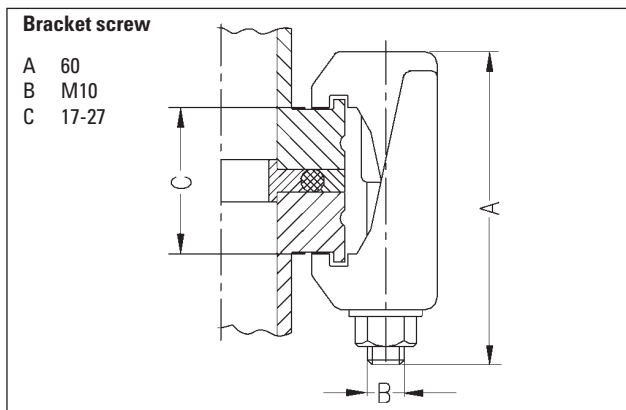

The person responsible for commissioning must ensure that the installation is carried out in accordance with the legal regulations and the pertinent industrial standards.

3.2. Installing The Pump, Connecting The High Vacuum Side



The utmost cleanliness must be observed when fitting all high vacuum parts. Unclean components prolong the pumping time.

Use a splinter shield

The use of a splinter shield (please see "Accessories") in the high vacuum flange protects the turbopump against foreign bodies coming from the vacuum chamber but does reduce the volume flow rate of the pump by approximately 15%. For fitting splinter shields please refer to "Fitting the splinter shield".

The high vacuum side can be flanged onto the vacuum chamber either directly or via a Pfeiffer Vacuum bellows or a vibration compensator (please see "Accessories").

Connecting via bellows

If the high vacuum side is to be flanged via a bellows, the turbopump must be secured for example via the holes on the underside of the turbopump (please see dimensions). The fastening must be able to withstand the torque referred to in Section 3.1.

Connecting via a Pfeiffer Vacuum vibration compensator



The maximum permissible temperature at the vibration compensator is 100 °C.

Where a Pfeiffer Vacuum vibration compensator is in use, a freely suspended turbopump can be flanged onto the vacuum chamber. Additional protective casing must be provided to take up the energy of the rotor in the event of a malfunction (please discuss this question with the manufacturer).

Directly flanging the pump

The turbopump can be flanged onto the vacuum chamber vertically (0°) up to an angle of 90° maximum.



The fore-vacuum flange must always point downwards.

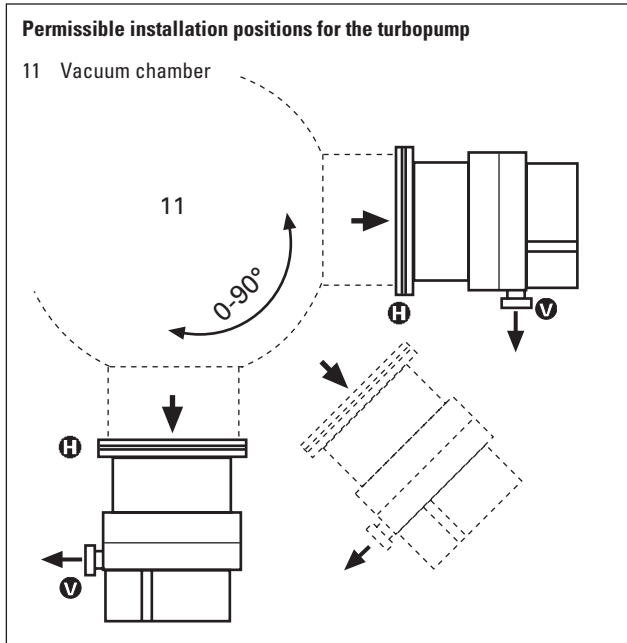

The maximum loading capacity of the high vacuum flange is 2000 N (equivalent to 200 kg). Asymmetric loading on the high vacuum flange must be avoided.

If the pump is being installed horizontally:
The fore-vacuum flange of the turbopump must be aligned vertically downwards (maximum deviation $\pm 15^\circ$), otherwise the turbopump could become dirty and the lubricating pump not properly function.

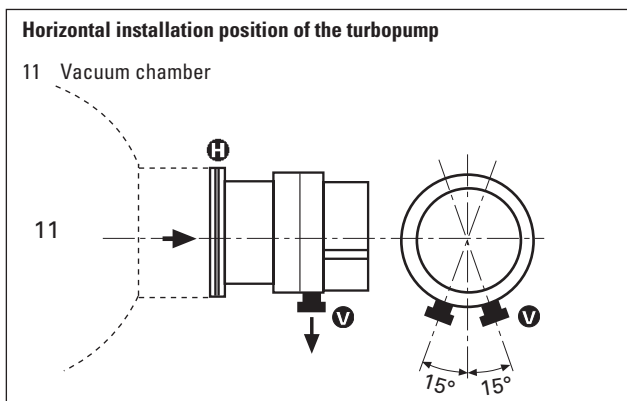

No forces from the piping system must be allowed to act on the pump where turbopumps are anchored. Suspend or support all pipes to the turbopump.

Fitting The Splinter Shield (Accessory)

➔ Insert the splinter shield in the ISO-K flange in condition on delivery.

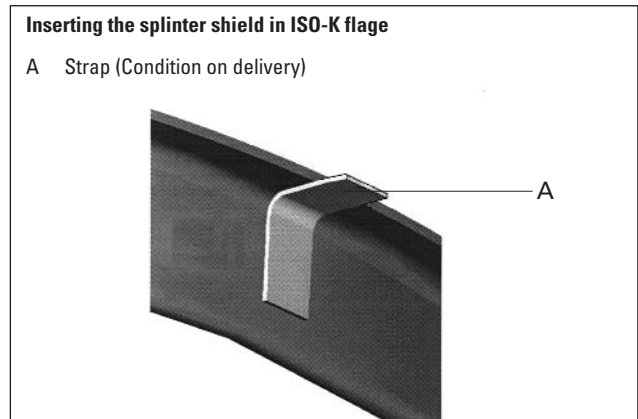

➔ Before insert the splinter shield in the CF-F flange the strap **must** be bent.

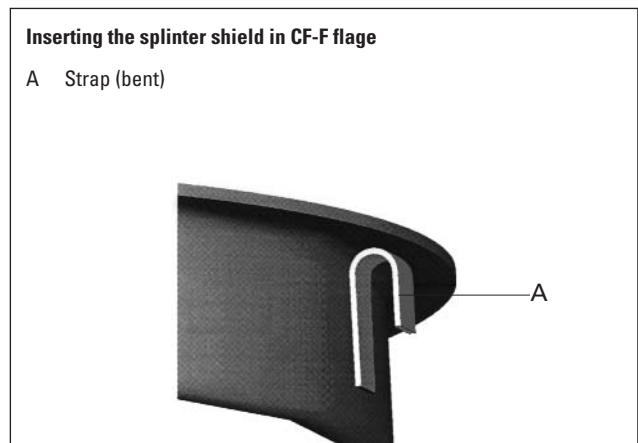

3.3. Connecting The Fore-Vacuum Side

Backing pump: Fore-vacuum pressure please see "Technical Data"

Recommendation: Oil-Free Diaphragm Pump or Rotary Vane Vacuum Pumps from the Pfeiffer range.

Vacuum

Connecting the backing pump

All connections of the fore-vacuum line: With the usual small flange components or screwed hoses.



Be sure to conduct away the exhaust gases from the backing pump. Do not reduce the free cross section of the fore-vacuum flange with following components.



The exhausted process gases and vapours can represent a health hazard and can also be environmentally damaging. Comply with all the gas manufacture's safety instructions.

- ➔ With rigid pipe connections: Fit a bellows in the connecting line to reduce vibration.
- ➔ The electrical connection of the backing pump is made via a relay box (Accessory) whose control line is connected to "FV PUMP" on the TC 600.

Please refer to Operating Instructions PT 800 030 BN for details on the relay box, backing pump and its installation.

3.4. Connecting The Cooling Unit

The Turbopumps TMH 1601 P/TMU 1601 P have been designed to be water cooled as standard. Air cooling, as an accessory, may only be used where the ambient temperature is $\leq 35^{\circ}\text{C}$.

The turbopumps TMH/TMU 1601 PC **must** be water cooled.

Water Cooling



The cooling water connections referred to here are in respect of the standard version turbopump.

The cooling water can be drawn either

- From the cooling water mains, or
- From Recycled Water Cooling Unit TZK in closed circuit.

Cooling from the cooling water mains

To prevent deposits collecting in the pump the cooling water must be filtered.

Minimum cooling water requirements:

Mechanically clean, optically clear, no turbidity, no sediment, chemically neutral, temperature $>$ dew point.

Oxygen content:	max. 4 mg/kg
Chloride content:	max. 100 mg/kg
Carbonate hardness:	max. 10 ° dH
Consumption of potassium permanganate:	max. 10 mg/kg
Carbon dioxide:	Undetectable
Ammonia:	Undetectable
pH-value:	7 – 9
Max. fore-line over pressure:	max. 6 bar
Minimum flow rate at gas load max.:	100 l/h at 15 °C

Connection to the cooling water mains

- ➔ Fit the dirt trap (Accessory) in the supply line.
- ➔ Connect the supply line with hose clips onto one of the two cooling water connections.
- ➔ Connect the return line to the other cooling water connection of the turbopump.
- ➔ Tighten the cooling water connection to a torque of 10 Nm.
- ➔ Tighten all hose clips and check for firm seating of the hoses.

Cooling from the cooling water mains

- 3 Cooling water connection
- 31 Supply line
- 32 Return line
- 33 Dirt trap

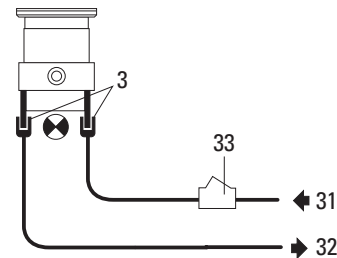

Cooling with the Recycled Water Cooling Unit TZK (Accessory)

Connection to the TZK

Dirt traps are not permissible in the lines. All other steps as for connecting to the cooling water mains.

Cooling with Recycled Water Cooling Unit TZK

- 3 Cooling water connection
- 35 Recycled Water Cooling Unit TZK

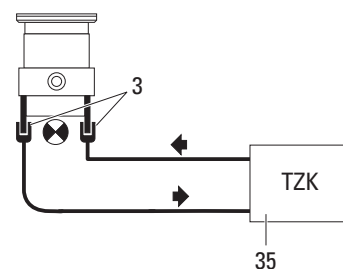

Air Cooling (Accessory)



Air cooling is only permissible for the TMH/TMU 1601 P and where the ambient temperature is $35\text{ }^{\circ}\text{C}$! Ensure that the supply and exhaust air ducts are not restricted. Only those air cooling units listed in this operating instruction manual in Section 11., "Accessories" may be used.

Please refer to Operating Instructions PM 800 543 BN for details and installation for air cooling.

3.5. Connecting The Venting Valve

The venting valve (Accessory) provides automatic venting in the event of a power failure and switching off.

Fitting the venting valve

- ➔ Unscrew the venting screw from the venting connection of the turbopump.
- ➔ Screw in venting valve with seal (USIT ring) on hexagonal SW 14.

Electrical connection

- ➔ Plug control lead 42a into the connection "VENT" of the TC 600 (8) on the turbopump.

The venting mode of the venting valve is selected via the DCU or Serial Interface RS 485.

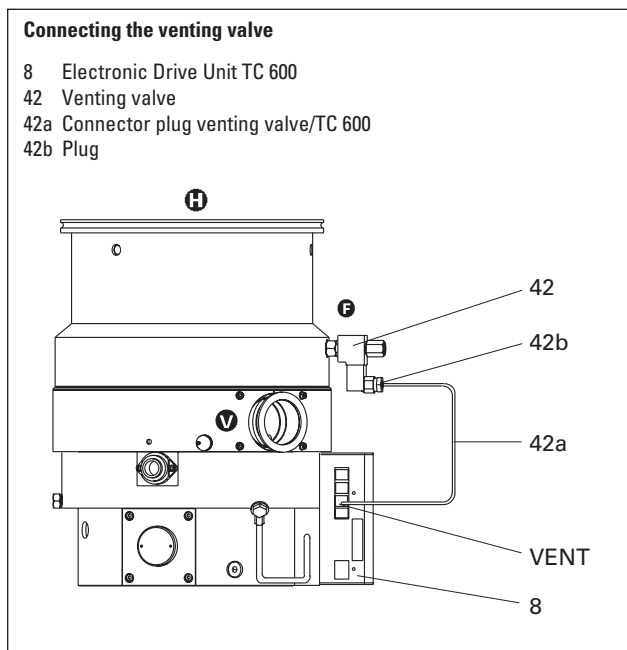

The maximum pressure at the venting valve is 1.5 bar absolute.

Please refer to Operating Instructions PM 800 507 BN for details on Venting Valve TVF 005.

3.6. Connecting The Casing Heating Unit (Accessory)

Heating turbopumps and vacuum chambers accelerates the attainment of final pressures. The heating period is dependent on the level of contamination and the required final pressure. Heat for at least four hours.



During operations with casing heating the turbopump must be operated with water cooling.



High temperatures are generated when turbopump or vacuum chamber are baked out. Contact with hot parts can cause burns, even when the casing heating has been switched off. Heating sleeves and pump casing should be insulated when fitting. Do not touch heating sleeves and pump casing during baking out.

Please refer to Operating Instructions PM 800 542 BN for details on the casing heating unit and its installation.

3.7. Connecting The Electronic Drive Unit TC 600



The turbopump and the Electronic Drive Unit TC 600 are connected and together form a single unit.
Connecting cable 8a has to be ordered separately (see "Accessories").

- ➔ Unscrew screw with tooth lock 8c from the TC 600 (above the connection X4).
- ➔ Plug the plug X4 on connecting cable 8a into the connection X4 on the TC 600 and screw in screw 8b.
- ➔ Secure plug X4 on the TC 600 with a screw and tooth lock 8c.
- ➔ Connect plug X2 on connecting cable 8a with power unit TPS 600/DCU 600 ("Accessories") on connection X2.
- ➔ Using screws and toothlock 8c (two pieces, included with the cable consignment) secure plug X2 to power unit 105.



Once operations voltage has been supplied, the TC 600 performs a self test on the supply voltage. The supply voltage for the turbomolecularpumps is 140 VDC \pm 5% in accordance with EN 60 742.

If the turbopump is to be operated with the Display and Operating Unit DCU 001/DCU 600, the remote plug 8d on the TC 600 should be disconnected and then proceed in accordance with Operating Instructions PM 800 477 BN.

3.8. Installing The Power Unit



Voltage may only be supplied with the Pfeiffer Vacuum power units (please see "Accessories").
The use of other power units requires the prior agreement of the manufacturer and equalization with the valid specification (power unit specifications available on request).



Operations with TPS 600/DCU 600 only possible in the connection voltage range 185-264 VAC.
For operations in the connected voltage range 90 - 132 VAC please refer to Operating Instructions "Pumping Operations With The DCU", PM 800 547 BN.

Please refer to Operating Instructions PM 800 521 BN for details on power unit TPS 600.

Connecting the TC 600 with Power Unit TPS 600/DCU 600

- X1 Mains connection
- X2 Connection, Power Unit TPS 600
- X4 Connection TC 600
- S1 ON/OFF switch
- 8 Electronic Drive Unit TC 600
- 8a Connecting cable, TC 600 – TPS/DCU
- 8b Screw
- 8c Screw with tooth lock (3 pieces)
- 8d Remote plug
- 105 Power Unit TPS 600

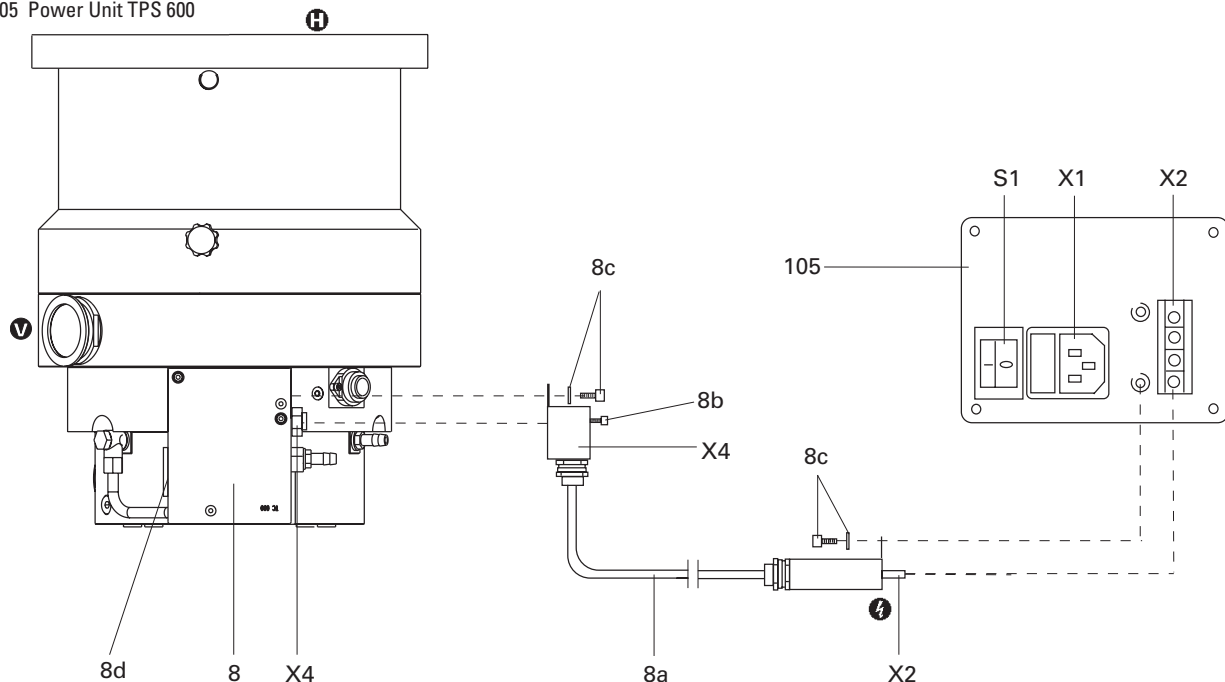

3.9. Connecting The Sealing Gas Valve

To protect the pump, particularly where corrosive or dust producing processes are involved, it is necessary to use sealing gas. Connection is made via the sealing gas valve (please see "Accessories").

Please refer to Section 9.1. "Dimensions Diagram" for the sealing gas connection.

Please refer to Operating Instructions PM 800 229 BN for details on installing the sealing gas valve and adjusting the sealing gas flow.

3.10. Connecting The Remote Control Unit

Remote control options for various functions are provided with the connection "REMOTE" on the TC 600 via the 10 pole screw connector plug (maximum cable cross section 0.14 - 1.5 mm²/connection).

Shielded cable should be used. Shielding has to be connected with the TC casing on the plug side of the TC 600 by using cable clamps.

The inputs 2 - 6 are activated by connecting them to the + 24V on pin 1 (active high) (please see Section 3.13. "Connections Diagram").

Pin Arrangement And Remote Plug Functions

(please see following table).



When connecting supply voltage, the turbopump is started.

On delivery:

Pin 1, Pin 2, Pin 3 and Pin 4 are bridged in the mating plug.

Pin arrangement and remote plug functions		
Pin Nr.	Input Open (low)	Input Closed (high) On + 24 V (pin 1)
1	+24 V	
2	venting blocked	venting release
3	motor, turbopump off	motor, turbopump on: the turbopump is driven, current flows through the motor coils.
4	pumping station off	pumping station on: the turbopump is driven, backing pump is activated.
5	heating off	heating on: the heating is switched on once the rotation speed switchpoint is attained and off when the rotation speed switchpoint is unattained.
5		Reset: by supplying a pulse (T < 2s) with an amplitude of 24V a malfunction acknowledgement can be processed.
6	standby off	standby on: pump is accelerated to 66% of its nominal rotation speed.
7	rotation speed setting mode off	the rotation speed can be changed by feeding a PWM signal to this pin or via Serial Interface RS 485 (see Section 4.9. "Rotation Speed Setting Mode")
8	Output (low) rotation speed switchpoint not attained	Output (high) set rotation speed switchpoint attained; output can be loaded with 24 V/50 mA
9	Output (low) collective malfunction message;	Output (high) malfunction-free operations output can be loaded with 24 V/50 mA
10	Mass (ground)	_____

3.11. Connecting The Serial Interface RS 485

An external operating component (DCU 001/DCU 600) or an external computer can be connected via the connection "RS 485" on the TC 600 with the use of an 8 pole modular connecting cable.

The serial interface is galvanically and safely separated from the maximum supply voltage from the TC 600.

Connection

Description	Value
Serial Interface Type:	RS 485
Baudrate:	9600 baud
data word lengths:	8 bit
Parity:	no (no parity)
Startbits:	1
Stopbits:	1..2

The electrical connections are internally optically decoupled.

PIN	Arrangement	RS 485
1	not connected	 1 ... 8 (View from the plug side of the TC 600)
2	+24V output (210 mA loading capacity)	
3	not connected	
4	not connected	
5	RS 485: D+ (DO / RI)	
6	Gnd — —	
7	RS 485: D- (DO / RI)	
8	not connected	



It is possible to connect an RS 232 (e.g. PC) via a level converter (please see "Accessories").

Connecting The RS 485

Connecting to a fixed bus system:

- ➔ Connect all units with D+ (pin 5/RS 485) and D- (pin7/RS 485) to the bus.
- ➔ The bus must be completed at both ends with R_T.

The connections should be made in accordance with the specification of the Serial Interface RS 485.

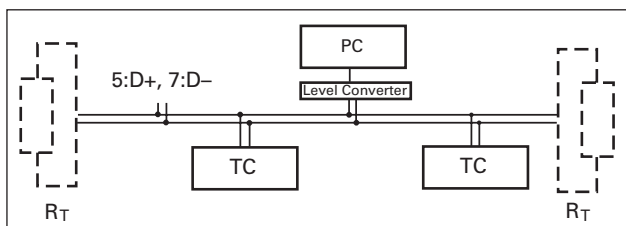

All units connected to the bus must have differing serial interface addresses (parameter 797).
The group address of the TC 600 is 960.



Only safety low voltages (SELV) may be connected to Serial Interface RS 485 .

All switched on remote functions have priority over the serial interface functions.



Please refer to the separate Operating Instructions PM 800 488 BN for more detailed information on operations via Serial Interface RS 485 and its electronic data.

Profibus DP Gateway TIC 250 is available (accessory) for connecting an Electronic Drive Unit TC 600 to a Profibus DP. Please refer to the respective Operating Instructions PM 800 599 BN for detailed information on the operation of the TIC 250.

3.12. Connecting The Temperature Management System (TMS)

Pumps with the designation TMH 1601 PCT/TMU 1601 PCT (please see the rating plate) can be heated to a maximum of 90 °C in the Holweck stages range with the heaters and temperature sensors (TMS) integrated in the middle casing.



During TMS operations the turbopump must be operated with water cooling.
During TMS operations the additional flange heating for the turbomolecular pump is not possible.

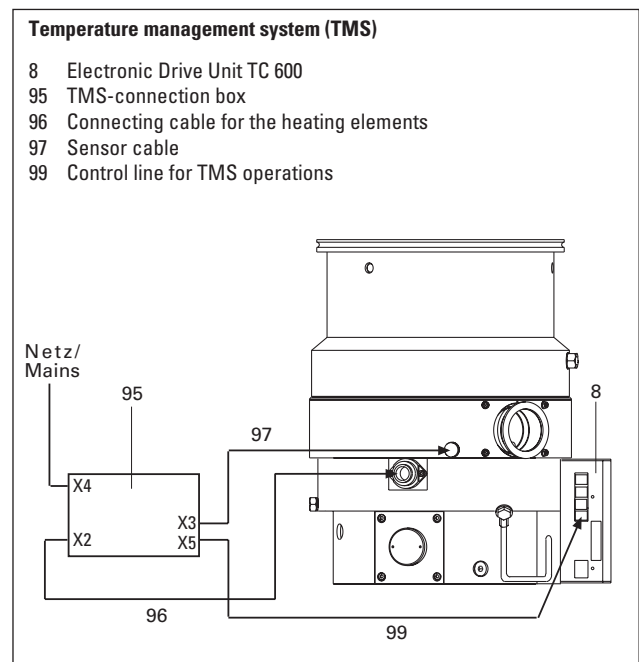

For connection and operation of the temperature management system (TMS) please refer to operating instructions for the TMS, PT 0099 BN.

3.13. Connections Diagram

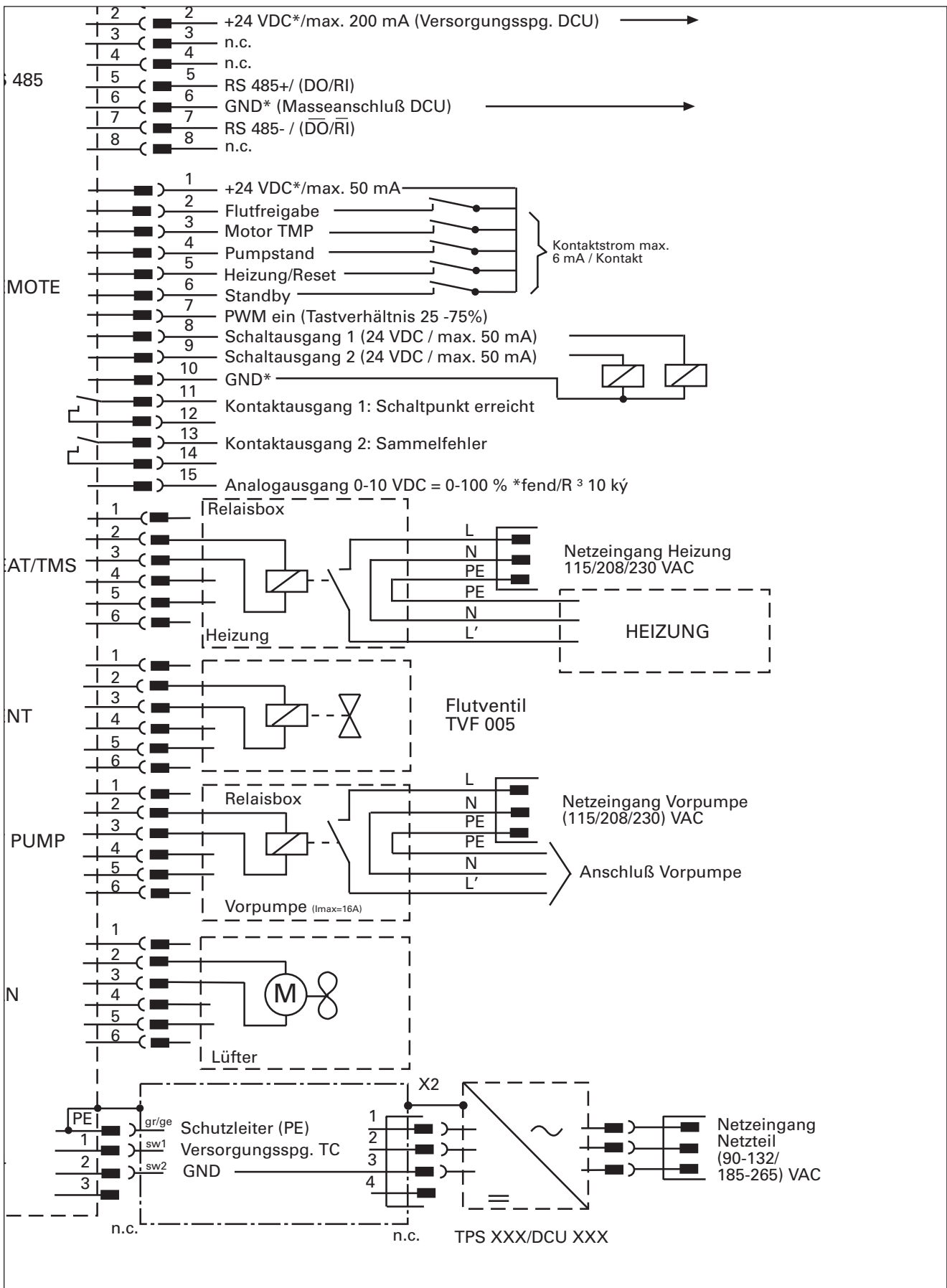

4. Operations

4.1. Filling In The Lubricant



Pumps must be filled with lubricant before being operated.

If possible fill in the lubricant in the fitting position of the pump.

Pumps are designed to operate with Lubricant "F3" contained with the delivery 65 cm³ (see rating plate).



If "F3" is heated above 300 °C, toxic vapours which can harm the airways are given off. Do not allow "F3" to come into contact with tobacco products (danger of poisoning when ignited). The precautions necessary in the handling of chemicals must be observed.

Filling in the lubricant

- ➔ Unscrew lubricant filler screw 71 and, using the syringe A provided, inject maximum 65 cm³ of lubricant.



If the pump is be operated in the vertical position, the sight glass should be half full with lubricant.

If the pump is be operated in the horizontal position, (fore-vacuum flange pointing down), the sight glass should be filled with lubricant up to the upper edge.

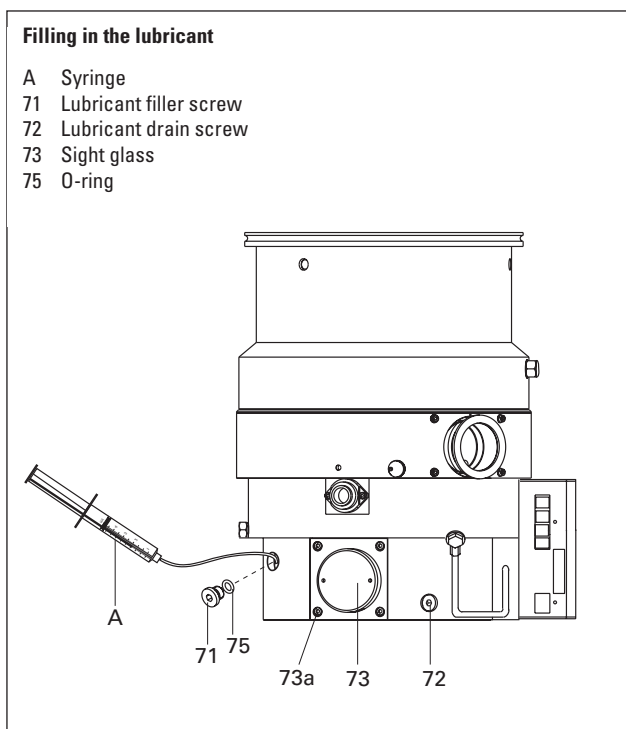

- ➔ Screw back in lubricant filler screw 71 with the O-ring 75.

f the turbopump is to be installed horizontally in movable system parts (for example, doors), such parts must be moved gently.



Where intense acceleration is involved, the lubricant can permeate the fore-vacuum chamber and cause contamination.

4.2. Before Switching ON

Sections 4.2 to 4.6. refer only to operating the pump in its condition on delivery, without the DCU operating unit. The bridges "venting release", "motor, TMP ON" and "pumping station ON" are fitted in the remote control plug.

Please refer to Section 4.8. regarding the switching on with the Operating And Display Control Unit DCU.



Turbopump rotors rotate at high speed. When the high vacuum flange is open there is a danger of injury and of damage to the pump caused by objects falling into the pump. Therefore never operate the pump with open high vacuum flange.

- ➔ With sealing gas: Open the sealing gas supply.
- ➔ With water cooling: Open cooling water supply and check flow.
- ➔ Plug connecting cable 8a ("Accessory") into the TC 600 and connect with Power Unit TPS 600 on X2 (please see Section 3.8.).

Please note:

The following pre-settings have been programmed:

- Start-up time 8 min
- Rotation speed switchpoint 80%
- Automatic venting 50%

These settings can only be altered via Serial Interface RS 485 (DCU or PC); please refer to the respective operating instructions.

4.3. Switching ON

- ➔ Switch on the turbopump with switch S1 on the power unit.
- Once the self test has been successfully completed on the TC 600 (duration approximately 20 seconds), both the turbopump and the backing pump begin operating.
- With air cooling the cooling fan is also switched on via Electronic Drive Unit TC 600.

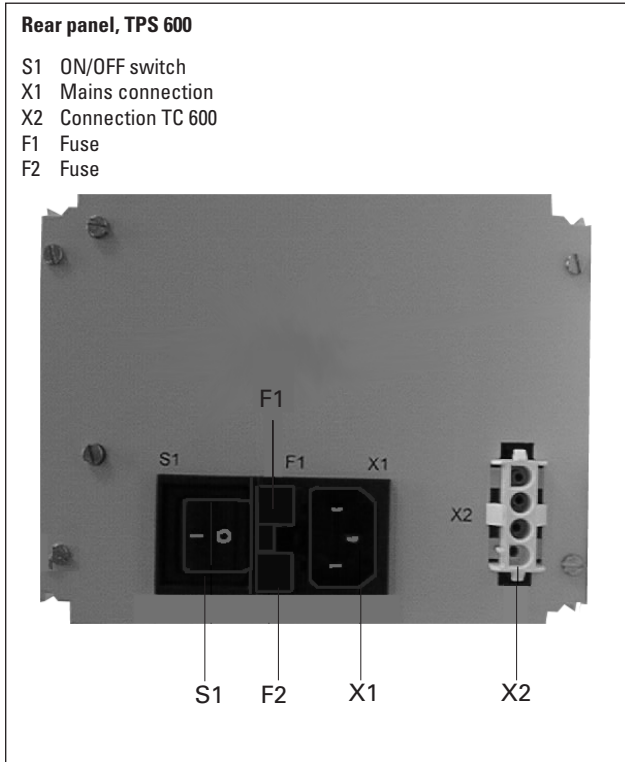

When the unit is switched on for the first time or after a lubricant change the contact to the lubricating pump can open as a result of the degassification of the lubricant. In such cases, as for other malfunctions, the electronic drive unit shuts down the turbopump.

- ➔ The turbopump must be re-started with switch S1 on the power unit.



Take care when pumping hazardous gases and observe the safety precautions of the gas manufacturer.

4.4. Gas Type Dependent Operations



Water cooling is required if the pumps are to be operated with gas load.

Where high level gas loads and rotation speeds are involved, the resulting friction subjects the rotor to the effect of great heat. To avoid over-heating, a power rotation speed characteristic line is implemented in the TC 600; this ensures that where maximum gas loads are involved, the pump will operate at any rotation speed without the danger of damage arising.

The maximum power is dependent on the type of gas. Two characteristic lines are available for any type of gas in order to fully exploit the power potential of the pump:

- "Gas-Mode 0" for gases with molecular mass ≥ 40 as, for example, Argon;
- "Gas-Mode 1" for all lighter gases.

Works setting: "Gas-Mode 0"

- ➔ Set the applicable gas mode on the TC 600 via the DCU (please refer to Operating Instructions "Pumping operations with the DCU" PM 800 547 BN).



Pumping gases with molecular mass ≥ 40 with the incorrect gas mode can cause damage to the pump.

For the vertex of the power characteristic line please refer to Section 8. Technical Data.

Maximum power is applied when the pump starts in order to limit the time required. Once the set rotation speed is attained, switching to the selected power characteristic line is automatic.

If the gas dependent maximum power is exceeded, the rotation speed is reduced until equilibrium between the permissible power and gas friction is attained. The power limitation serves to protect the pump against thermal over-loading. In order to avoid rotation speed fluctuations it is recommended to set, in rotation speed setting mode, the equilibrium frequency or a somewhat lower frequency.



There can be types of pump whereby there is no differentiation between the two "gas modes" settings.

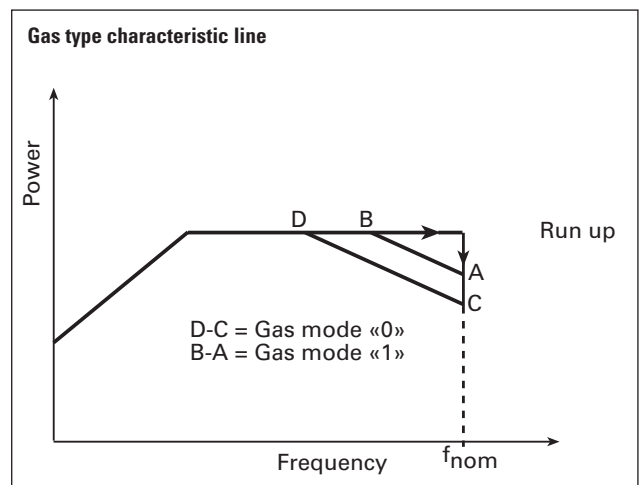

4.5. Circulatory Lubrication

The ball bearing on the fore-vacuum side is supplied with lubricant via the lubricating pump.

The circulation of the lubricant is monitored via a switching contact. If there is insufficient lubricant, the electronic drive unit switches off the turbopump. Monitoring is active only from 60% of the final rotation speed.

If, at a rotation speed of > 60% of the final rotation speed (for example through the degassification of the lubricant), the contact opens for 2 minutes, the electronic drive unit assumes a lubricant deficiency and switches off the turbopump.

- ➔ Check the filling level of the lubricant.
- ➔ Re-start the turbopump with switch S1 on the power unit.

4.6. Switching OFF And Venting

To avoid contamination occurring when switching off, the pump should be vented before shut-down.

- ➔ Switch off both turbopump and backing pump on the power unit at the same time with switch S1.
Where corrosive gas processes are involved, the sealing gas supply should be shut off after approximately 10 minutes and both turbo pump and backing pump switched off with switch S1.

➔ Venting

There are three possibilities to vent turbopump:

- **Manual venting** with the use of the venting screw (status on delivery).
- **Venting with the venting valve** which is selectable via the remote control (please see Section 4.9.), or via the DCU (see Operating Instructions, "Pumping Operations With The DCU", PM 800 547 BN).
- **Venting in two stages** when the vacuum chamber should be vented as quickly as possible. First stage: venting with a pressure increase rate of 15 mbar/s for 20 seconds. Second stage: venting with an optionally large venting valve.

The valve cross-section for a venting rate of 15 mbar/s must be compatible with the size of the vacuum chamber. Where small vacuum chambers are involved, the Pfeiffer Vacuum Venting Valve TVF 005 can be used for first stage venting.

- ➔ Shut off water supply.

4.7. Shutting Down For Longer Periods



Vacuum pumps are sometimes used to pump aggressive or hazardous gases. There is a danger of personal injury resulting from coming into contact with process gases. Before removing a turbopump from the system, first:

- Vent the turbopump with a neutral gas or dry air.
- Ensure that there is no residual process gas in the system nor in the feeder lines.

If the turbopump is to be shut down for more than a year:

- ➔ Remove turbopump from the system.
- ➔ Change the lubricant (see Section 7.1.).
- ➔ Close the high vacuum flange and evacuate the turbopump via the fore-vacuum flange.
- ➔ Vent turbopump via the venting connection with nitrogen or dry air.
- ➔ Close fore-vacuum and venting connection by blank flanging.
- ➔ Place the pump vertically on its rubber feet.
- ➔ In rooms with moist or aggressive atmospheres, the turbopump must be air-sealed in a plastic bag together with a bag of desiccant, e.g. silicagel.



If the pump has been shut down for **3 years** a bearing change must be carried out (please get in touch with Pfeiffer Vacuum Service).

4.8. Operations With The DCU 001 / DCU 600

Operations with the DCU 001 or DCU 600 should be carried out in accordance with the relevant Operating Instructions PM 800 477 BN (DCU description) and PM 800 547 BN (operating the pump with the DCU).



Operations with the DCU 001/DCU 600, the remote plug 8d on the TC should be disconnected (please see Section 2.1.).

4.9. Operations With The Remote Control Unit

(please refer to the table in Section 3.10.).

Remote control operations can be performed via the connection with the designation "REMOTE" on the TC 600. The connection is via a 10 pole screwed connector plug with the following arrangement:

- 1 - + 24V
- 2 - Input, venting
- 3 - Input, turbopump motor
- 4 - Input, pumping station
- 5 - Input, heating unit
- 6 - Input, Standby
- 7 - Input, PWM
- 8 - Switching output 1: Rotation speed switchpoint
- 9 - Switching output 2: Collective malfunction message
- 10 - Mass

Inputs 2-6 are activated if they are connected with the +24 V on pin 1 (active high).



On delivery there is a bridge between Pin 1, Pin 2, Pin 3 and Pin 4 on the TC 600 mating plug.

When operations voltage is supplied and a successfully completed TC 600 self-test the turbopump and any connected backing pump will be started.

Venting Release (Optional)

Automatic venting:

When the turbopump or pumping station is switched off the venting valve opens for the venting time of 3600 seconds (1 hour) when the venting frequency falls below 50% of the final rotation speed (330 Hz). In the event of a mains power failure if the venting frequency falls below 50% of the final rotation speed the venting valve opens and closes on attainment of 15% of the final rotation speed.

Venting OFF:

Venting does not take place.

Other venting modes:

Other venting modes can be selected via the DCU.

Motor, Turbopump

When the pumping station is switched on and once the self test has been successfully completed (duration approximately 20 seconds), the turbopump is set in operation. During operations, the turbopump can be switched on and off while the pumping station is switched on.

Pumping Station

Any connected pumping station components are started up (e.g. backing pump, venting valve, air cooling) and with simultaneous activation of the input "motor, turbopump" the turbopump is set in operation once the self test has been successfully completed (duration approximately 20 seconds).

Heating/Reset

Heating (optional)

Once the rotation speed switchpoint is attained the heating unit is switched on; when the rotation speed switchpoint is fallen below the heating unit is switched off.

Reset

The heating input has two functions (please refer to the table in Section 3.10., point 5 "Reset").

Standby

The pump can be operated optionally at 66% of its nominal rotation speed (standby ON) or at its nominal rotation speed (standby OFF).

Rotation Speed Setting Operations

Via Input PWM

The supply of pulse width modulated signals (PWM) with a ground frequency of 100 Hz $\pm 20\%$ with an amplitude of maximum 24 V and a touch ratio of 25-75% enables the rotation speed to be set in the range from 20-100% of the nominal rotation speed.

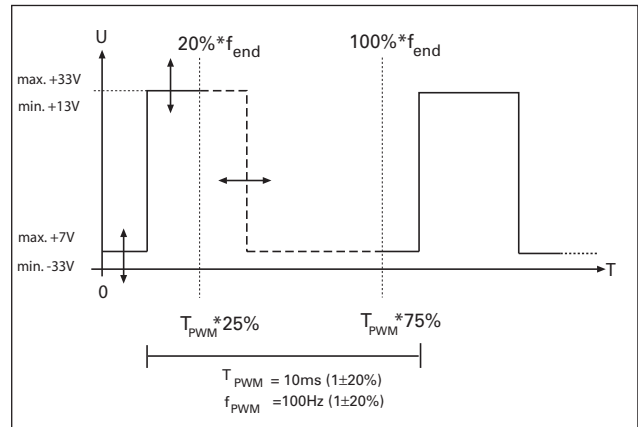

If no signal is present the pump runs up to its final rotation speed.

Available as accessories:

- A PWM adapter box for rotation speed setting operations for the turbopump.
- A Brake Unit TBU 600 which enables, in rotation speed setting mode, faster braking on turbopumps.

Switching Outputs

Switching outputs 1 and 2 can be loaded with a maximum 24 V / 50 mA per output. The following functions are assigned to the switching outputs:

Switching output 1: Active high when the rotation speed switchpoint is attained. The switchpoint for the turbopump is set at 80% of the nominal rotation speed. It can be used, for example, for a message "pump ready to operate".

Switching output 2: Active low with a collective malfunction message (see Section 6.).

The connection of a relay is made between pin 10 (mass) and the respective switching output pin 8 or pin 9 (see Section 3.13. Connections Diagram).

5. Monitoring Operations

5.1. Operations Display Via LED

Certain operations modes of the turbopump and the TC 600 can be ascertained via the two integrated LEDs located on the front panel of the TC 600.

The following operations modes are displayed:

LED		Cause
I	L	
glows green		<ul style="list-style-type: none"> – Power unit OK – Function "pumping station ON" carried out
flashes green		<ul style="list-style-type: none"> – Power unit OK – Pumping station OFF
blinks green		<ul style="list-style-type: none"> – Mains power supply failure
	glows red	<ul style="list-style-type: none"> – Collective malfunction (for example, start-up time error, excess temperature, turbopump or TC 600, lubricant deficiency) – Switching output 2 active (low)
	blinks red	<ul style="list-style-type: none"> – Warning (for example, earth leakage fault in the voltage supply, mains power supply failure)

5.2. Turbopump Temperature Monitoring

Where impermissible motor temperatures are involved or the temperature of the TC 600 casing is too high, the motor current is reduced. This can lead to dipping below the set rotation speed switchpoint and results in the turbomolecular pump being switched off.

LED on the TC 600 glows red: Collective malfunction.



Differentiated malfunction and warning signals are only possible with the use of the DCU.

6. What To Do In Case Of Breakdowns?

Problem	Possible Causes	Remedy
Pump doesn't start; None of the integrated LEDs glow on the TC 600 repair	<ul style="list-style-type: none"> • Power supply interrupted • Incorrect operations voltage supplied • Pins 1-3 and 1- 4 on the remote-plug not connected • No supply of operations voltage • Defect TC 600 • Reduction in the voltage in the cable 	<ul style="list-style-type: none"> • Check fuse in the power unit • Check plug contacts on the power unit • Check power unit feeder line • Check voltage on the power unit (140 VDC) at connection X2 • Supply correct operations voltage • Connect pins 1-3 and 1- 4 on the remote plug • Check plug contacts on the power unit • Inform Pfeiffer Vacuum Service of need for • Use suitable cable
Pump doesn't attain nominal rotation speed within the set - start-up time; Pump cuts out during operations	<ul style="list-style-type: none"> • Fore-vacuum pressure too high • Leak or too high levels of gas load • Rotor sluggish caused by defective bearing • TC start-up time too short • Thermal overloading caused by: <ul style="list-style-type: none"> – Insufficient water flow – Insufficient air supply – Fore-vacuum pressure too high – Ambient temperature too high • Lubricant or lubricating pump dirty • Lubricant deficiency 	<ul style="list-style-type: none"> • Check backing pump function • Check seals • Seek leak and repair • Reduce gas load • Check bearing (noises?): Request Pfeiffer Vacuum Service to replace • Set longer start-up time with the DCU or PC • Ensure free flow • Ensure adequate air supply • Reduce fore-vacuum pressure • Reduce ambient temperature • Carry out lubricant change as per Section 7.1. or clean the lubricating pump as per Section 7.2. • Check lubricant and replace as necessary
Pump doesn't attain final pressure	<ul style="list-style-type: none"> • Pump dirty • Leak in vacuum chamber, lines or pump 	<ul style="list-style-type: none"> • Bake out pump • If seriously contaminated: Request Pfeiffer Vacuum Service to clean • Seek leak starting with vacuum chamber • Repair leak
Unusual operating noises repair	<ul style="list-style-type: none"> • Bearing damaged • Rotor damaged • Splinter shield (if fitted) not seated firmly 	<ul style="list-style-type: none"> • Inform Pfeiffer Vacuum Service of need for • Inform Pfeiffer Vacuum Service of need for • Check seat of splinter shield (see Section 3.2.)
Red LED on the TC 600 glows	<ul style="list-style-type: none"> • Collective malfunction 	<ul style="list-style-type: none"> • Reset via mains OFF/ON or remote pin 5 • Different malfunction display with a DCU possible ¹⁾
Red LED on the TC 600 blinks	<ul style="list-style-type: none"> • Warning from: <ul style="list-style-type: none"> – Mains power failure – Supply voltage short 	<ul style="list-style-type: none"> • Different warning display with a DCU is possible ¹⁾ • Ccheck power unit voltage • Check the power unit mains connection

1) Without a DCU inform Pfeiffer Vacuum Service to check the cause of trouble.

7. Maintenance



No liability for personal injury nor material damage will be accepted for damages and operational interruptions which have been caused by improper maintenance; in addition, all guarantees become invalid.

You can change the lubricant yourself. Please contact your local Pfeiffer Vacuum Service for all other maintenance and service work.



Ensure no mechanical forces act on the Electronic Drive Unit TC 600.

7.1. Replacing The Lubricant

The lubricant should be replaced at least once a year. Where extreme operating conditions or unclean processes are involved, the replacement interval should be checked with your Pfeiffer Vacuum Service Center.



Lubricant drain screw 72 may only be opened if the turbopump has been vented to atmospheric pressure.



Drain of and fill in the lubricant in the fitting position if possible. If it is absolutely necessary to dismantle the pump to change the lubricant, this may only be carried out in the position shown in Section 3.2. otherwise the lubricant could contaminate the pump.

- ➔ Switch off the turbopump, vent to atmospheric pressure (see Section 4.6.) and allow to cool as necessary.
- ➔ Unscrew lubricant drain screw and drain lubricant into a suitable container.
- ➔ Screw back in lubricant drain screw with the O-ring.
- ➔ Unscrew lubricant filler screw. Using the syringe provided inject maximum 65 cm³ of lubricant as per the rating plate (please see Section 4.1. for the lubricant level).
- ➔ Screw in lubricant filler screw with the O-ring.



Lubricants can contain toxic substances from the medium pumped. Lubricant must be disposed of in accordance with the respective regulations. Safety instructions data sheet for the lubricant on request.

7.2. Cleaning The Lubricating Pump

If, following a malfunction, the pump does not accelerate to its operational rotation speed on account of insufficient lubricant, the lubricating pump must be cleaned.



The Electronic Drive Unit TC 600 must only then be disconnected from the turbopump when the pump is at a standstill and the TC 600 is disconnected from the power supply.

- ➔ Drain lubricant and dispose of as described in Section 7.1.
- ➔ Unscrew the two Allan head screws from the Electronic Drive Unit TC 600 and disconnect the TC from the pump.
- ➔ Unscrew hollow screw 19 and remove cooling plate 18 from the turbopump; take care with flat sealing 19a (2 pieces).

Detach the lubricating pump as follows and drain the remaining lubricant:

- ➔ Unscrew screws 82 (each 4 pieces) and remove flanges 81 and 100; take care with O-ring 101.
- ➔ Disconnect plug 83 with connecting cable from the lubricating pump.
- ➔ Screw a screw 82 into the threaded hole (M4) provided on the side of flange 81 in the lubricating pump and carefully detach the pump with the help of pointed pliers.



Do not detach the lubricating pump from the sight glass side because this would damage the sieve 103. Be careful to avoid damaging the sealed surfaces.

- ➔ Clean the lubricating pump and boring in the lubricant reservoir using a clean, fluff-free cloth.
- ➔ Dismantle the lubricating pump in accordance with the following diagram and clean. **Caution!** Exclusively pure alcohol must be used as a cleaning agent.
- ➔ Force out pin 80 in order to remove floater 79. When re-fitting, the floater head should point to the pin.
- ➔ Re-assemble lubricating pump; take care with O-ring 74.
- ➔ The groove on the lubricating pump must be positioned in the centering pin in lubricant reservoir 64.
- ➔ Re-fit the flanges 81 and 100 with O-rings 101.
- ➔ Screw in lubricant drain screw 72 with O-ring 75.
- ➔ Fill in maximum 65 cm³ of lubricant in accordance with Section 7.1.
- ➔ Re-connect the Electronic Drive Unit TC 600 to the pump.

Lubricating pump

- 8 Electronic drive unit
- 8c Securing screw (2 pieces)
- 18 Cooling plate
- 19 Hollow screw
- 19a Flat sealing
- 64 Lubricant reservoir
- 71 Lubricant filler screw
- 72 Lubricant drain screw
- 73 Sight glass
- 74 O-ring
- 75 O-ring
- 76 O-ring
- 77 Lubricating pump
- 79 Floater
- 80 Pin
- 81 Flange
- 82 Securing screw (8 pieces)
- 83 Plug
- 94 Contact
- 100 Flange
- 101 Seal
- 103 Sieve

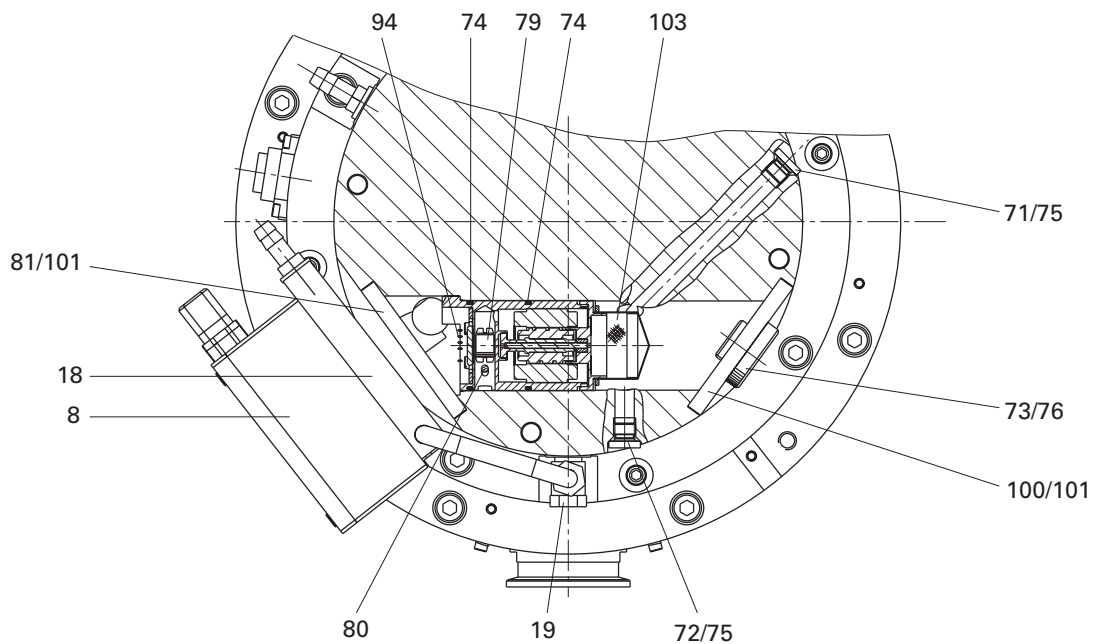
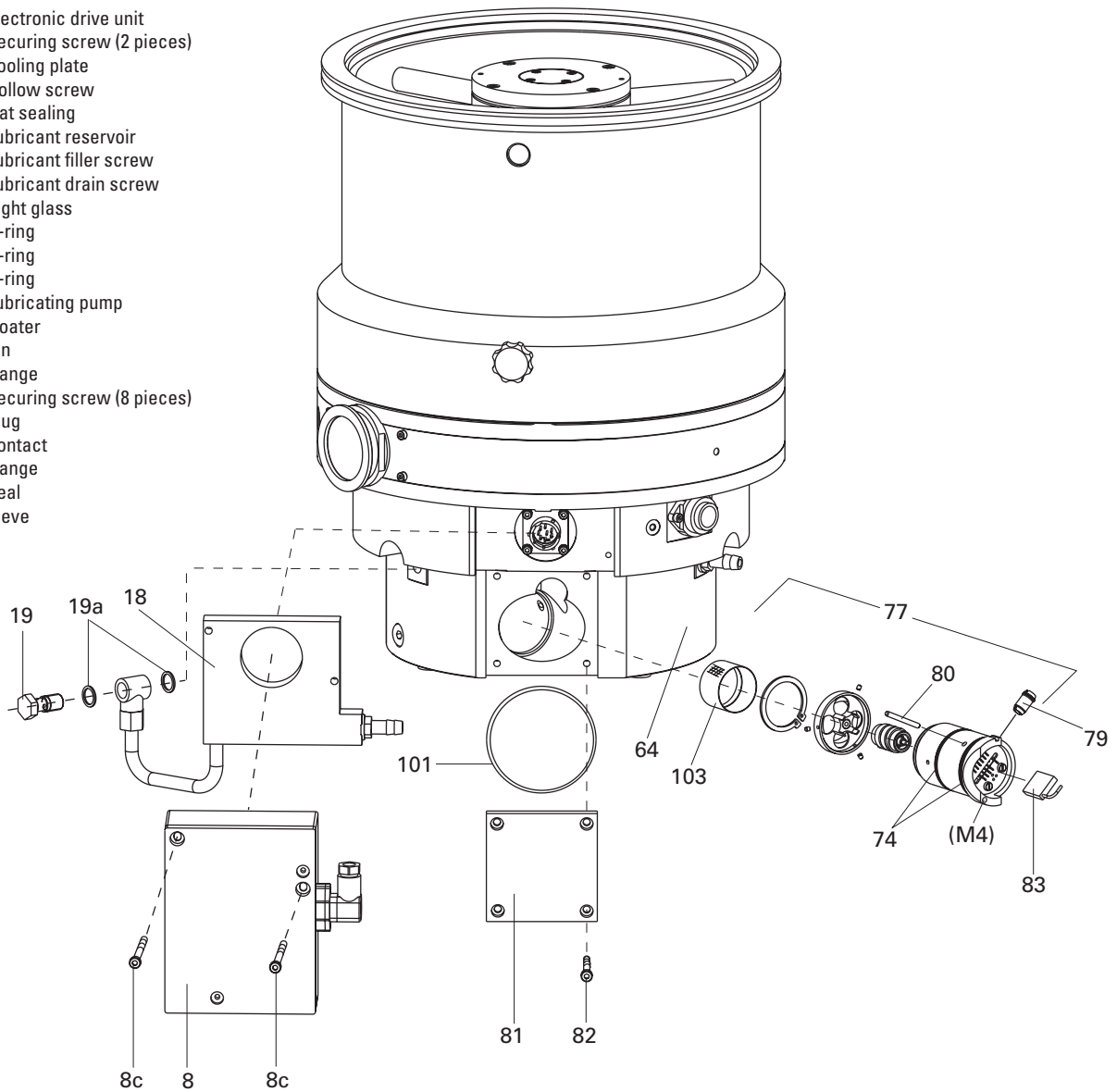

8. Service

Do make use of our service facilities

In the event that repairs are necessary a number of options are available to you to ensure any system down time is kept to a minimum:

- Have the pump repaired on the spot by our Pfeiffer Vacuum Service Engineers;
- Return the pump to the manufacturer for repairs;
- Replace the pump.

Local Pfeiffer Vacuum representatives can provide full details.



Please take into account that where Pfeiffer Vacuum Service replacement service is involved the standard operating parameters are always pre-set.

If your application requires different parameters, please modify accordingly.



The turbopump and the Electronic Drive Unit TC form a single unit and must therefore be returned complete for repair purposes. Before returning the unit it should be ensured that the power unit is not the cause of the malfunction (please see Section 5. for checking the power unit).

Before returning:

- ➔ Detach all accessories.
- ➔ Please attach a clearly visible notice "Free of harmful substances" (both on the unit and also on the delivery note and any accompanying letters).

"Harmful substances" are substances and preparations as defined in the current, local, dangerous substances regulations; in the U.S.A. as "materials in accordance with the Code of Federal Regulations (CFR) 49 Part 173.240 Definition and Preparation". We will carry out the decontamination and invoice this work to you if you have not attached this note.

This also applies where the operator does not have the facilities to carry out the decontamination work.

Fill out the declaration of contamination

- ➔ In every case the "Declaration of Contamination" must be completed diligently and truthfully.
- ➔ A copy of the completed declaration must accompany the unit; any additional copies must be sent to your local Pfeiffer Vacuum Service Center.

Please get in touch with your local Pfeiffer Vacuum representatives if there are any questions regarding contamination.



Decontaminate units before returning or possible disposal. Do not return any units which are microbiologically, explosively or radioactively contaminated.

Returning contaminated units

If contaminated have to be returned for maintenance/repair, the following instructions concerning shipping must be followed:

- ➔ Neutralise the pump by flushing with nitrogen or dry air.
- ➔ Seal all openings to the air.
- ➔ Seal pump or unit in suitable protective foil.
- ➔ Ship units only in appropriate transport containers.



Repair orders are carried out according to our general conditions of sale and supply.

If repairs are necessary, please send the pump together with a short failure description to your nearest Pfeiffer Vacuum Service Center.

Contact addresses and telephone hotline

Contact addresses and telephone numbers can be found on the back cover of these operating instructions.

9. Technical Data

Feature	Unit	TMH 1601 P TMU 1601 P	TMH 1601 P TMU 1601 P	TMH 1601 P C H (T) TMU 1601 P C H (T)	TMH 1601 P C H (T) TMU 1601 P C H (T)
Connection nominal diameter: Inlet		DN 200 ISO-K DN 200 CF-F	DN 250 ISO-K DN 250 CF-F	DN 200 ISO-K DN 200 CF-F	DN 250 ISO-KF DN 250 CF-F
Outlet Venting connection		DN 40 ISO-KF G 1/8"		DN 40 ISO-KF G 1/8"	
Nominal rotation speed	Hz (1/min)	600 (36 000)		600 (36 000)	
Standby rotation speed	Hz (1/min)	400 (24 000)		400 (24 000)	
Start-up time (up to 90% of the nominal rotation speed fore-vacuum pressure $\leq 0,1$ mbar)	min	6		6	
Noise level	dB (A)	47		47	
Final pressure, backing pump	mbar	≤ 5		≤ 2.5	
Maximum permissible rotor temperature	°C	120		120	
Permissible heat radiation power	W	35		35	
Volume flow rate for:					
Nitrogen N ₂	l/s	1000	1400	1000	1400
Helium He	l/s	1100	1200	1100	1210
Hydrogen H ₂	l/s	750	900	750	900
Compression ratio for:					
N ₂		10 ¹¹		$> 10^9$	
He		$2 \cdot 10^7$		$1 \cdot 10^5$	
H ₂		$2 \cdot 10^5$		$5 \cdot 10^3$	
Maximum fore-vacuum pressure					
N ₂	mbar	14		5	
He	mbar	12		4,5	
H ₂	mbar	6		2	
Maximum gas throughput ^{1) 2) 3)} with HV pressure of 0.1 mbar					
N ₂	mbar/s	22		24	
Ar	mbar/s	—		27	
with nominal rotation speed (water cooling)					
N ₂	mbar/s	12		18	
Ar	mbar/s	7		12	
with voltage range 90 - 132 VAC					
N ₂	mbar/s	9		15	
Vertex power characteristics lines ⁴⁾					
A	W / Hz	520 / 600		520 / 600	
B	W / Hz	560 / 450		560 / 450	
C	W / Hz	480 / 600		480 / 600	
D	W / Hz	520 / 348		520 / 348	
Final pressure ⁵⁾					
with diaphragm vacuum pump	mbar	$< 5 \cdot 10^{-10}$		$< 1 \cdot 10^{-8}$	
with rotary vane vacuum pump	mbar	$< 5 \cdot 10^{-10}$		$< 1 \cdot 10^{-8}$	
with UniDry TM	mbar	$< 5 \cdot 10^{-10}$		$< 1 \cdot 10^{-8}$	
Lubricant Type ⁶⁾		F3		F3	
Filling volume	cm ³	65		65	
Cooling water consumption with water at 15 °C ⁷⁾	l/h	100		100	
Cooling water temperature	°C	5 - 25		5 - 25	
Permissible ambient temperature with air cooling	°C	0 - 35		—	
Power consumption:					
Casing heating unit	W	170		170	
TMS heating	W	—		1000	
Weight	kg	49/51	51/53	49/51	51/53
Permissible magnetic field	mT	3		3	
Connection voltage	VDC	140 \pm 5%		140 \pm 5%	
Current consumption	A	4.3		4.3	
Power	W	600		600	
Protection class ⁸⁾		IP 30		IP 30	
Relative humidity of air	%	5 - 85 non condensing		5 - 85 non condensing	

Please refer to the next page for explanations.

- 1) Measured with a rotary vane vacuum pump > 5m³/h, higher gas throughputs with reduced rotation speed.
- 2) In TMS operations the maximum gas throughput is reduced with increasing TMS temperature.
- 3) If the pump is to be operated with more than 50% of the maximum gas load, sealing gas must be used.
- 4) For gas type characteristics lines please refer to Section 4.4. Where pumps for TMS operations are involved, the corner points reduce according to the temperature; the values are available on request.

- 5) In accordance with DIN 28 428 the final pressure of a turbomolecular pump is that pressure which is attained in a measuring dome 48 hours after baking out.
- 6) See rating plate.
- 7) With maximum gas throughput.
- 8) Protection class IP 54 is afforded for the Electronic Drive Unit TC 600 by retro-fitting a cover plate (accessory).

9.1. Dimensions Diagram

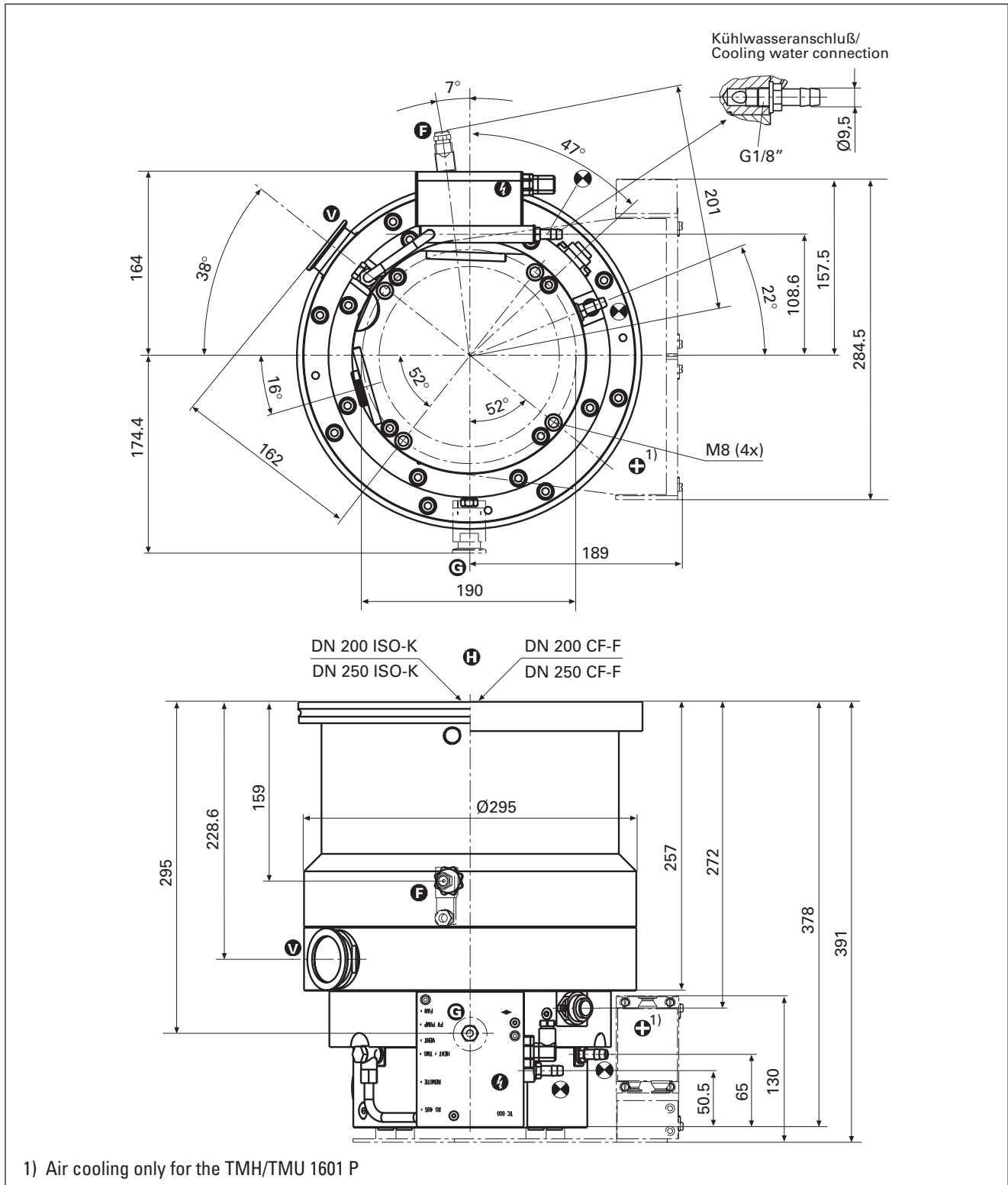

10. Spare Parts

Pos.	Description	Pieces	Size	Number	Comments	Ordering Quantity
	Spare parts TMH/TMU 1601 P TMH/TMU 1601 PC					
	Set of seals TMH/TMU 1601 P TMH/TMU 1601 PC	1		PM 093 104 T PM 093 079 T		
8d	Remote plug	1		P 0920 668 E		
17	USIT-ring	1		P 3529 133 -A		
19a	Flat sealing (Cu)	2		P 0995 294		
71	Lubricant filler screw	1		N 3191 382 X		
72	Lubricant drain screw	1		N 3191 382 X		
73	Sight glass	1		PM 003 251		
74	O-ring	2	36 x 2	P 4070 594 PV		
75	O-ring	2	6 x 2,2	P 4070 088 PV		
76	O-ring	2	22 x 3	P 4070 384 PV		
77	Lubricating pump	1	(for F3)	PM 083 449 AT		
79	Floater	1		PM 033 306 -X		
87	O-ring	1	44 x 3	P 4070 703 PV		
101	O-ring	2	59 x 3	P 4070 874 PV		
103	Sieve	1		PM 093 062		

Spare Parts

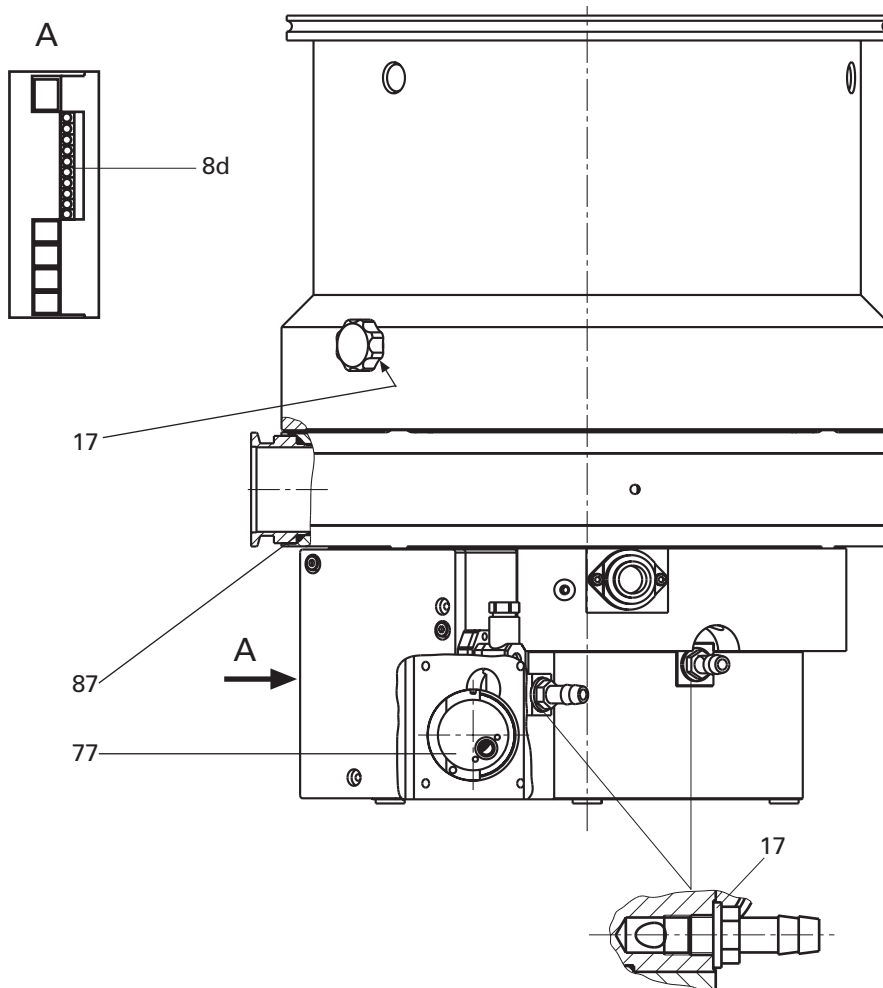

Spare Parts

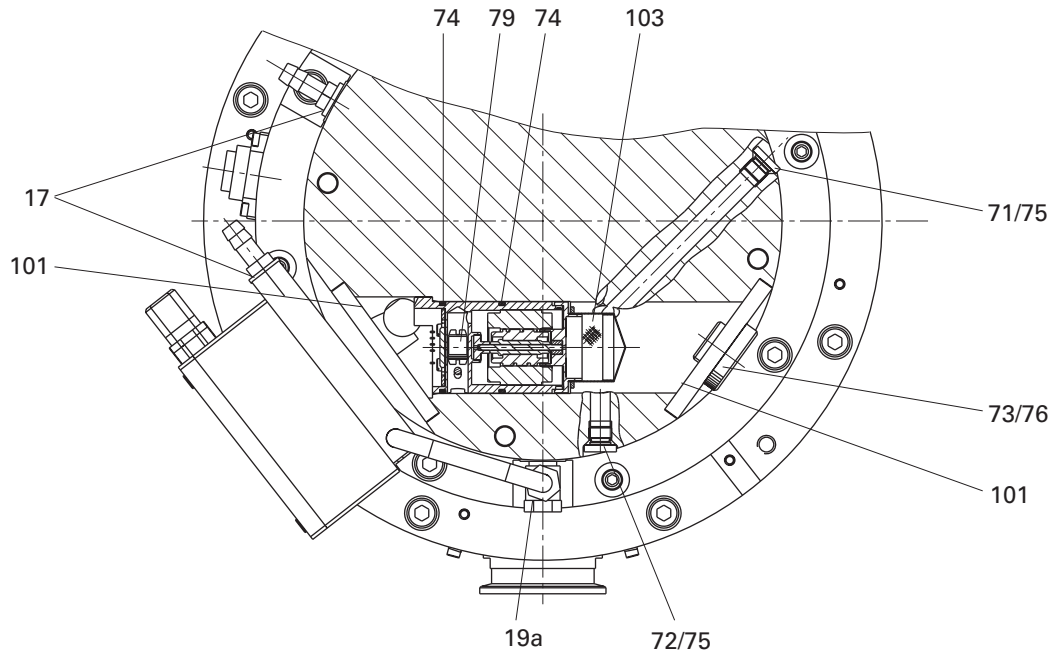

11. Accessories

Description	Size	Number	Comments/ Operating Instructions	Order Quantity
Components for cooling				
Dirt trap	R 3/8"	P 4161 300 2R		
Recycled Water Cooling Unit TZK 400	230 V, 50 Hz	PM Z01 245	PM 800 369 BN Only for the TMH/TMU 1601 P/ PM 800 543 BN	
Air cooling	24 VDC	PM Z01 250		
Components for venting				
Venting Valve TVF 005, without current closed	24 VDC	PM Z01 135	PM 800 507 BN	
Drying Unit TTV 001 (filled with zeolite)		PM Z00 121	PM 800 022 BN	
Venting flange	DN 10 ISO-KF	PM 033 737 -T		
Components for heating				
Casing Heating	230 V, safety plug 208 V, UL plug 115 V, UL plug	PM 041 912 -T PM 041 913 -T PM 041 914 -T	Water coolind required/ PM 800 542 BN PM 800 542 BN PM 800 542 BN	

Description	Size	Number	Comments/ Operating Instructions	Order Quantity
Other accessories				
Connecting cable, TC 600-TPS/DCU	3 m	PM 051 103 GT	other lengths on request	
Power Unit				
– TPS 600; for fitting to walls or standard runners		PM 041 815 -T	PM 800 521 BN	
– TPS 600; 19" insert unit		PM 041 821 -T	PM 800 521 BN	
– DCU 600; 19" insert unit with Operating and Display Control Unit (DCU)		PM C01 697	PM 800 477 BN	
Mains cable				
Safety plug	230 V	P 4564 309 ZA		
UL plug	208 V	P 4564 309 ZF		
UL plug	115 V	P 4564 309 ZE		
Operating and Display Control Unit DCU 001		PM 041 816 -T	PM 800 477 BN	
Relay box, backing pump	5 A 20 A	PM 041 937 AT PM 041 938 -T	PT 800 030 BN PT 800 030 BN	
PWM adapter box		PM 051 028 -U	PM 800 563 BN	
Cover plate for TC 600 (IP 54)		PM 051 327 -T	PT 0024 BN	
Profibus-DP gateway TIC 250		PM 051 257 -T	PM 800 599 BN	
Level converter RS 232/485		PM 051 054 -X	PM 800 549 BN	
Brake Unit TBU 600		PM 051 368 -T	PT 800 018 BN	
Vibration compensator, TMH				
TMU	DN 200 ISO-K DN 250 ISO-KF DN 200 CF-F DN 250 CF-F	PM 006 668-X PM 006 670 -X PM 006 669 -X PM 006 671 -X		
Protective mesh	DN 200 DN 250	PM 016 039 AX PM 016 077 -X		
Splinter shield	DN 200 DN 250	PM 006 985 AX PM 006 984 AX		
Sealing ring, TMH	DN 200 DN 250	PF 303 120 -T PF 303 125 -T		
Collar flange with retaining ring, TMH	DN 200-F DN 250-F	PF 307 120 -T PF 307 125 -T		
Cu seal (10 pieces), TMU (5 pieces)	DN 200 CF DN 250 CF	PF 501 420 -T PF 501 425 -T		
Set of screws, TMU	DN 200 CF DN 250 CF	PF 505 003 -T PF 505 003 -T		
Hose nipple	DN 16 ISO-KF-10	PF 144 020	for use please see Section 3.9.	
Sealing gas valve	DN 10 ISO-KF	PM Z01 142	PM 800 229 BN	
Fore-Vacuum Safety Valve TVV 001	115 V 230 V	PM Z01 206 PM Z01 205	PM 800 263 BN	
Syringe		PM 006 296 -U		

11.1.Lubricant

Lubricant	Amount	Order Number	Order Quantity
F3	0,05 l 0,25 l	PM 006 336 -T PM 006 313 -T	

When ordering accessories and spare parts please be sure to state the full part number. When ordering spare parts please state additionally the unit type and unit number (see rating plate). Please use this list as an order form (by taking a copy).

Declaration of Contamination of Vacuum Equipment and Components

The repair and/or service of vacuum components will only be carried out if a correctly completed declaration has been submitted. Non-completion will result in delay.

The manufacturer could refuse to accept any equipment without a declaration.

This declaration can only be completed and signed by authorised and qualified staff:

1. Description of component:

- Equipment type/model: _____
- Code No.: _____
- Serial No.: _____
- Invoice No.: _____
- Delivery Date: _____

2. Reason for return:

3. Equipment condition

- Has the equipment been used?
yes no
- What type of pump oil was used?

- Is the equipment free from potentially harmful substances?
yes (go to section 5)
no (go to section 4)

4. Process related contamination
of equipment

- toxic yes no
- corrosive yes no
- microbiological hazard*) yes no
- explosive*) yes no
- radioactive*) yes no
- other harmful substances yes no

*) We will not accept delivery of any equipment that has been radioactively or microbiologically contaminated without written evidence of decontamination!

Please list all substances, gases and by-products which may have come into contact with the equipment:

Tradename Product name Manufacturer	Chemical name (or Symbol)	Danger class	Precautions associated with substance	Action if spillage or human contact
1.				
2.				
3.				
4.				
5.				

5. Legally Binding Declaration

I hereby declare that the information supplied on this form is complete and accurate. The despatch of equipment will be in accordance with the appropriate regulations covering Packaging, Transportation and Labelling of Dangerous Substances.

Name of Organisation: _____

Address: _____ Post code: _____

Tel.: _____

Fax: _____ Telex: _____

Name: _____

Job title: _____

Date: _____ Company stamp: _____

Legally binding signature: _____

Herstellereklärung *Manufacturer's Declaration*

im Sinne folgender EU-Richtlinien:
pursuant to the following EU directives:

- **Maschinen/Machinery 98/37/EG**
- **Elektromagnetische Verträglichkeit/Electromagnetic Compatibility 89/336/EWG**
- **Niederspannung/Low Voltage 73/23/EWG**

Hiermit erklären wir, dass das unten aufgeführte Produkt zum Einbau in eine Maschine bestimmt ist und dass deren Inbetriebnahme so lange untersagt ist, bis festgestellt wurde, dass das Endprodukt den Bestimmungen der EU-Richtlinie 98/37/EG, Anhang II B entspricht.

Wir bestätigen Konformität mit der EU-Richtlinie über elektromagnetische Verträglichkeit 89/336/EWG und der EU-Niederspannungsrichtlinie 73/23/EWG.

We hereby certify that the product specified below is intended for installation in a machine which is forbidden to be put into operation until such time as it has been determined that the end product is in accordance with the provision of EU Directive 98/37/EEC, Annex II B.

We certify conformity with EU Electromagnetic Compatibility Directive 89/336/EEC and EU Low Voltage Directive 73/23/EEC.

Produkt/Product:

TMH 1601 P / TMU 1601 P

TMH1601 PCHT / TMU 1601 PCHT

Angewendete Richtlinien, harmonisierte Normen und angewendete, nationale Normen:

Guidelines, harmonised standards, national standards in which have been applied:

**EN 292-1, EN 292-2, EN 294,
EN 1012-2, EN 61010**

Unterschrift/*Signature:*



Pfeiffer-Vacuum GmbH
Berliner Strasse 43
D-35614 Asslar
Germany

(W. Dondorf)
Geschäftsführer
Managing Director

Herst.l/2000

Vacuum is nothing, but everything to us!



Turbo Pumps



Rotary Vane Vacuum Pumps



Roots Pumps



Dry Vacuum Pumps



Leak Test Units



Valves



Flanges, Feedthroughs



Vacuum Measurement



Gas Analysis



System Technology



Service

PFEIFFER  **VACUUM**

Pfeiffer Vacuum Technology AG · Headquarters/Germany

Tel. +49-(0) 64 41-8 02-0 · Fax +49-(0) 64 41-8 02-2 02 · info@pfeiffer-vacuum.de · www.pfeiffer-vacuum.net